

My Lecture Note

Phayuth

January 2, 2024

Contents

1	Transfer Function	7
1.1	Example of Determine a Transfer Function	7
1.2	Example of Determine System from TF	9
2	1st Order Differential Equation	11
2.1	Method of Solving 1st Order Homogeneous Differential Equation	11
2.1.1	Method of Separation of Variable	11
2.2	Method of Solving 1st Order Non-Homogeneous Differential Equation	12
2.2.1	Method of Variable Substitution	12
2.2.2	Method of Integrating Factor	14
3	2nd Order Differential Equation	15
3.1	Method of Solving 2nd Order Homogeneous Differential Equation	15
3.1.1	Method of Using Characteristic Equation	15
3.2	Method of Solving 2nd Order Non-Homogeneous Differential Equation	17
3.2.1	Method of Undetermined Coefficients	18
4	2nd Order ODE Standard Form	21
4.1	Spring Mass Damper Modeling	21
4.1.1	Distinct Real Roots	22
4.1.2	Double Real Root	22
4.1.3	Complex Root	23
4.2	Discussion of Each Cases	23
4.2.1	Over-damped Case ($\zeta > 1$)	23
4.2.2	Critically damped Case ($\zeta = 1$)	23
4.2.3	Under damped Case ($\zeta < 1$)	24
5	Partial Fraction Decomposition	27
5.1	Case 1: Distinct Real Poles	27
5.2	Case 2: Repeated Real Poles	29
5.3	Case 3: Complex Conjugate Poles	31
5.4	Improper Complex Function	32
6	Laplace and Inverse Laplace Transform	33
6.1	Laplace Transform	33
6.1.1	Laplace of Dirac Delta Function	34
6.1.2	Laplace of Unit Function	34
6.1.3	Laplace of $f(t) = e^{-at}$	34
6.1.4	Laplace of $f(t) = t$	34

6.1.5	Laplace of Integral of a Function	35
6.1.6	Laplace of Derivative of a Function	35
6.1.7	Final Value Theorem	36
6.2	Inverse Laplace Transform	37
6.2.1	Case 1: Distinct Real Poles	37
6.2.2	Case 2: Repeated Real Poles	37
6.2.3	Case 3: Complex Conjugate Poles	37
6.3	Poles Location and Time Domain Response	37
7	State Space Representation	41
7.1	Forming State Space	41
7.2	State Space of Scalar Differential Equation System	45
7.2.1	Case 1	45
7.2.2	Case 2	46
7.3	Transfer Function to State Space	47
7.4	State Space to Transfer Function	48
8	Linear Approximation with Taylor Series	51
8.1	Superposition	51
8.2	Homogeneous	51
8.3	Linearization Process	52
9	DC Motor	55
9.1	Modelling	55
9.1.1	Electrical Part	55
9.1.2	Mechanical Part	56
9.1.3	Approximation of coulomb friction to zero $T_c \approx 0$	57
9.1.4	Keep coulomb friction T_c	57
9.1.5	Electrical and Mechanical combine	57
9.1.6	Approximation of coulomb friction to zero $T_c \approx 0$	57
9.1.7	Keep coulomb friction T_c	58
9.2	Simulation	58
9.3	DC Motor 2nd Order Model (L_a is not Neglected)	59
9.3.1	No Friction	59
9.3.2	With Friction	60
10	DC Motor Lamped Parameters Identification	61
10.1	DC Motor Stochastic State Space Model	61
10.1.1	Model with neglect the coulomb friction	61
10.1.2	Model the coulomb friction	63
10.2	Identification using Extended Kalman Filter(EKF)	64
10.2.1	Model with neglect the coulomb friction	64
10.2.2	Model with coulomb friction	66
11	DC Motor Control	69
11.1	Velocity Control using PI Control	69
11.2	Velocity Control using PID Control	70
11.3	Position Control using PID Control	72

12 DC Motor Cascade Control	75
12.1 Outer P Velocity and Inner PI Torque Control Design	75
13 Kalman Filter	79
13.1 Kalman Filter (Linear System)	79
13.2 Extended Kalman Filter (Nonlinear System)	80
13.3 Unscented Kalman Filter (Nonlinear System)	81
14 Sensor Fusion	83
14.1 Differential Drive Robot Sensor Fusion for Linear and Angular Velocity .	83
14.1.1 From Wheel Encoder	83
14.1.2 From IMU Sensor	84
14.1.3 Estimate V	84
14.1.4 Estimate ω	86
14.2 Three Wheels Omnidrive Robot Sensor Fusion for Linear and Angular Velocity	88

Chapter 1

Transfer Function

Transfer Function is the ratio of Laplace Transform of Output of the system to the Laplace Transform of Input of the system, when all the initial condition are assumed to be zero. (Very important that if it is not zero then the system is not Linear Time Invariant)(We can not take a Laplace Transform of a nonlinear system). Let:

- $x(t)$ is Input of the system
- $y(t)$ is Output of the system
- $h(t)$ is the system

We have:

$$y(t) = x(t) * h(t) \quad (1.1)$$

Taking Laplace Transform, We get:

$$Y(s) = X(s) * H(s) \quad (1.2)$$

By convolution property:

$$\boxed{H(s) = \frac{Y(s)}{X(s)}} \quad (1.3)$$

1.1 Example of Determine a Transfer Function

System 1 Determine a Transfer Function of a system below:

$$\frac{d^2y(t)}{dt^2} + 3\frac{dy(t)}{dt} + 2y(t) = x(t)$$

Solution We have:

- $x(t)$ is Input of the system
- $y(t)$ is Output of the system

Taking Laplace Transform of the system:

$$\mathcal{L}\left[\frac{d^2y(t)}{dt^2} + 3\frac{dy(t)}{dt} + 2y(t)\right] = \mathcal{L}[x(t)]$$

We get:

$$\mathcal{L}\left[\frac{d^2y(t)}{dt^2}\right] = s^2Y(s) - sY(0^-) - y'(0^-)$$

$$\mathcal{L}\left[3\frac{dy(t)}{dt}\right] = 3[sY(s) - y(0)]$$

$$\mathcal{L}[2y(t)] = 2Y(s)$$

$$\mathcal{L}[X(t)] = X(s)$$

$$s^2Y(s) - sY(0^-) - y'(0^-) + 3[sY(s) - y(0)] + 2Y(s) = X(s)$$

Put Initial Condition to zero, we get:

$$s^2Y(s) + 3sY(s) + 2Y(s) = X(s)$$

$$Y(s)[s^2 + 3s + 2] = X(s)$$

$$\rightarrow \frac{Y(s)}{X(s)} = \frac{1}{s^2 + 3s + 2}$$

$$\rightarrow H(s) = \frac{1}{s^2 + 3s + 2}$$

$$\rightarrow \boxed{H(s) = \frac{1}{(s+1)(s+2)}}$$

System 2 Determine a Transfer Function of a system below:

$$\dot{\phi}(t) = k(\phi_{ref}(t) - \phi(t))$$

Solution

$$\frac{1}{k}\dot{\phi}(t) = \phi_{ref}(t) - \phi(t)$$

$$\frac{1}{k}\dot{\phi}(t) + \phi(t) = \phi_{ref}(t)$$

Taking Laplace Transform of the system:

$$\mathcal{L}\left[\frac{1}{k}\dot{\phi}(t) + \phi(t)\right] = \mathcal{L}[\phi_{ref}(t)]$$

We have:

- $\phi_{ref}(t)$ is Input of the system
- $\phi(t)$ is Output of the system

$$\frac{1}{k}sY(s) + Y(s) = X(s)$$

$$Y(s)\left[\frac{1}{k}s + 1\right] = X(s)$$

$$\rightarrow \frac{Y(s)}{X(s)} = \frac{1}{\frac{1}{k}s + 1}$$

$$\rightarrow \boxed{H(s) = \frac{1}{\frac{1}{k}s + 1}}$$

System 3 Determine a Transfer Function of a system below:

$$\ddot{\phi}(t) = k(\phi_{ref}(t) - \phi(t))$$

Solution

$$\frac{1}{k}\ddot{y}(t) + y(t) = x(t)$$

Taking Laplace Transform of the system:

$$\mathcal{L}\left[\frac{1}{k}\ddot{y}(t) + y(t)\right] = \mathcal{L}[x(t)]$$

$$\frac{1}{k}s^2Y(s) + Y(s) = X(s)$$

$$Y(s)\left[\frac{1}{k}s^2 + 1\right] = X(s)$$

$$\rightarrow \boxed{H(s) = \frac{1}{\frac{1}{k}s^2 + 1}}$$

System 4 Determine a Transfer Function of a system below:

$$\ddot{y}(t) + ky(t) = kx(t)$$

Solution Taking Laplace Transform of the system:

$$s^2Y(s) + kY(s) = kX(s)$$

$$Y(s)[s^2 + k] = kX(s)$$

$$\rightarrow \boxed{H(s) = \frac{k}{s^2 + k}}$$

1.2 Example of Determine System from TF

Below is a system transfer function that transfer wheel position θ to wheel velocity $\dot{\theta}$. Determine the system function and discretize it. We have a TF:

$$\frac{Y(s)}{X(s)} = \frac{s}{as + 1}$$

$$(as + 1)Y(s) = sX(s)$$

$$asY(s) + Y(s) = sX(s)$$

Taking a Reverse Laplace Transform:

$$ay(t) + y(t) = \dot{x}(t)$$

$$\rightarrow \boxed{\dot{y}(t) = -\frac{1}{a}y(t) + \frac{1}{a}\dot{x}(t)}$$

Discretize the model:

$$\begin{aligned}\frac{y_{k+1} - y_k}{T_s} &= -\frac{1}{a}y_k + \frac{1}{a}\frac{x_{k+1} - x_k}{T_s} \\ y_{k+1} - y_k &= -\frac{T_s}{a}y_k + \frac{1}{a}(x_{k+1} - x_k) \\ y_{k+1} &= y_k - \frac{T_s}{a}y_k + \frac{1}{a}(x_{k+1} - x_k) \\ y_{k+1} &= \left(1 - \frac{T_s}{a}\right)y_k + \frac{1}{a}(x_{k+1} - x_k) \\ \rightarrow \dot{\theta}_{k+1} &= \left(1 - \frac{T_s}{a}\right)\dot{\theta}_k + \frac{1}{a}(\theta_{k+1} - \theta_k)\end{aligned}$$

Chapter 2

1st Order Differential Equation

Differential equation is set an equation that its solution is a function and involve of its derivative. In engineering, these equations is usually used to govern a dynamics system model and the rate of change of state. In 1st Order Differential Equation is equation consist of first derivative of function in form:

$$\frac{dy}{dx} + P(x)y = Q(x)$$

Where :

- $P(x)$ is function of x
- $Q(x)$ is function of x

2.1 Method of Solving 1st Order Homogeneous Differential Equation

2.1.1 Method of Separation of Variable

Method

When to use the Method All y, dy term and x, dx can explicitly move to different side of the equation. For example:

$$\begin{aligned}\frac{dy}{dx} &= 5xy \\ \rightarrow \frac{dy}{y} &= 5xdx\end{aligned}$$

How to use the Method

- Step 1 : Move all y, dy term and x, dx to different side of the equation.
- Step 2 : Integrate both side with respect to dx and dy respectively.
- Step 3 : Simplify the equation.

Example Solve:

$$\frac{dy}{dx} = 5xy$$

- Step 1

$$\frac{dy}{y} = 5x dx$$

- Step 2

$$\int \frac{1}{y} dy = 5 \int x dx$$

$$\ln|y| = \frac{5}{2}x^2 + c$$

- Step 3

$$\ln|y| = \frac{5}{2}x^2 + c$$

$$e^{\ln|y|} = e^{\frac{5}{2}x^2 + c}$$

$$y = e^{\frac{5}{2}x^2 + c}$$

$$y = e^{\frac{5}{2}x^2} e^c$$

$$y = Ce^{\frac{5}{2}x^2} \leftarrow \text{Solution}$$

2.2 Method of Solving 1st Order Non-Homogeneous Differential Equation

2.2.1 Method of Variable Substitution

Method

When to use the Method Use in general form of 1st order linear differential equation of:

$$\frac{dy}{dx} + P(x)y = Q(x)$$

How to use the Method

- Step 1 : Substitute $y = uv$ and $\frac{dy}{dx} = u\frac{dv}{dx} + v\frac{du}{dx}$ to equation.
- Step 2 : Factoring v out. example: $v(\text{term}_u, \text{term}_x)$.
- Step 3 : Put v term equal to zero and solve for u using separation of variable.
- Step 4 : Substitute u back to equation Step 2 where v term is zero and Solve for v .
- Step 5 : After getting u and v , substitute back into $y = uv$ for a solution of function.

Example Solve:

$$\frac{dy}{dx} - \frac{y}{x} = 1$$

- Step 1

$$u \frac{dv}{dx} + v \frac{du}{dx} - \frac{uv}{x} = 1$$

- Step 2

$$u \frac{dv}{dx} + v \left(\frac{du}{dx} - \frac{u}{x} \right) = 1$$

- Step 3

$$\begin{aligned} \left(\frac{du}{dx} - \frac{u}{x} \right) &= 0 \\ \frac{du}{dx} &= \frac{u}{x} \\ \frac{du}{u} &= \frac{dx}{x} \\ \int \frac{du}{u} &= \int \frac{dx}{x} \\ \ln|u| &= \ln|x| + C \\ \ln|u| &= \ln|x| + \ln|K| \leftarrow \text{let } C = \ln|k| \text{ make easier} \\ u &= Kx \end{aligned}$$

- Step 4

$$\begin{aligned} Kx \frac{dv}{dx} &= 1 \\ dv &= \frac{1}{Kx} dx \\ \int dv &= \frac{1}{K} \int \frac{1}{x} dx \\ v &= \frac{1}{K} (\ln|x| + D) \\ v &= \frac{1}{K} \ln|Lx| \end{aligned}$$

- Step 5

Our Solution is:

$$y = uv = Kx \frac{1}{K} \ln|Lx| = x \ln|Lx|$$

2.2.2 Method of Integrating Factor

Method

Use in general form of 1st order linear differential equation of:

$$\frac{dy}{dx} + P(x)y = Q(x)$$

How to use the Method

- Step 1 : Calculate Integrating Factor $I(x) = e^{\int P(x)dx}$.
- Step 2 : Multiply both side of the equation by $I(x)$
- Step 3 : Form $\frac{d}{dx}(y.I(x)) = I(x)Q(x)$ and Integrate both side by dx .
- Step 4 : Solve for y and simplify.

Example Solve:

$$\cos(x)\frac{dy}{dx} + \sin(x)y = 1$$

Then :

$$\frac{dy}{dx} + \tan(x)y = \frac{1}{\cos(x)}$$

We have $P(x) = \tan(x)$ and $Q(x) = \frac{1}{\cos(x)}$

- Step 1

$$I(x) = e^{\int P(x)dx} = e^{\int \tan(x)dx} = e^{\ln|\sec(x)|} = \sec(x)$$

- Step 2

$$\sec(x)\frac{dy}{dx} + \sec(x)\tan(x)y = \sec(x)\frac{1}{\cos(x)}$$

$$\sec(x)\frac{dy}{dx} + \sec(x)\tan(x)y = \sec^2(x)$$

- Step 3

$$\frac{d}{dx}(y.\sec(x)) = \sec^2(x)$$

$$\int \frac{d}{dx}(y.\sec(x))dx = \int \sec^2(x)dx$$

$$y.\sec(x) = \int \sec^2(x)dx$$

$$y.\sec(x) = \tan(x) + C$$

- Step 4

$$y.\sec(x) = \tan(x) + C$$

$$y = \frac{\tan(x) + C}{\sec(x)}$$

$$y = \sin(x) + C\cos(x)$$

Chapter 3

2nd Order Differential Equation

Differential equation is set an equation that its solution is a function and involve of its derivative. In engineering, these equations is usually used to govern a dynamics system model and the rate of change of state. In 2nd Order Differential Equation is equation consist of second and first derivative of function in form:

$$\frac{d^2y}{dx^2} + P(x)\frac{dy}{dx} + Q(x)y = f(x)$$

3.1 Method of Solving 2nd Order Homogeneous Differential Equation

The 2nd Order Homogeneous Differential Equation has the form of:

$$\frac{d^2y}{dx^2} + P(x)\frac{dy}{dx} + Q(x)y = 0$$

3.1.1 Method of Using Characteristic Equation

Method

Where Does it come from ? We propose a solution the 2nd Order Homogeneous Differential Equation above where:

$$y = e^{rx}$$

Thus

$$\frac{d^2y}{dx^2} = r^2e^{rx}$$

$$\frac{dy}{dx} = re^{rx}$$

Substitute to the equation:

$$\begin{aligned} r^2e^{rx} + P(x)re^{rx} + Q(x)e^{rx} &= 0 \\ e^{rx}(r^2 + P(x)r + Q(x)) &= 0 \end{aligned}$$

The term e^{rx} can not go to zero, thus the term $r^2 + P(x)r + Q(x)$ will go to zero. The term $r^2 + P(x)r + Q(x)$ is the second order polynomial equation where we have three different form of solution.

- $\Delta > 0$ the equation has 2 distinct real roots r_1 and r_2
- $\Delta = 0$ the equation has repeated real root r
- $\Delta < 0$ the equation has 2 complex conjugated roots $r_1 = \alpha + \beta i$ and $r_2 = \alpha - \beta i$

If:

- $\Delta > 0$ the solution has a form of $y = Ae^{r_1x} + Be^{r_2x}$
- $\Delta = 0$ the solution has a form of $y = Ae^{rx} + Bxe^{rx}$
- $\Delta < 0$ the solution has a form of
 - $y = Ae^{(\alpha+\beta i)x} + Be^{(\alpha-\beta i)x}$
 - $y = e^{\alpha x}(Ae^{\beta ix} + Be^{-\beta ix})$
 - $y = e^{\alpha x}(A\cos(\beta x) + iB\sin(\beta x))$ (From euler's formula $e^{ix} = \cos(x) + i\sin(x)$)

How to use it

- Step 1 : Form a Characteristic Equation from the equation $ar^2 + br + c = 0$.
- Step 2 : Find Δ and roots of the equation.
- Step 3 : Plug the result into three of the solution form and determine the constants using initial condition.

Example 1 Solve:

$$\frac{d^2y}{dx^2} - 9\frac{dy}{dx} + 20y = 0$$

- Step 1

$$r^2 - 9r + 20 = 0$$

- Step 2

$$\Delta > 0, r_1 = 4, r_2 = 5$$

- Step 3

$$y = Ae^{4x} + Be^{5x}$$

Example 2 Solve:

$$\frac{d^2y}{dx^2} - 10\frac{dy}{dx} + 25y = 0$$

- Step 1

$$r^2 - 10r + 25 = 0$$

- Step 2

3.2. METHOD OF SOLVING 2ND ORDER NON-HOMOGENEOUS DIFFERENTIAL EQUATION

$$\Delta = 0, r = 5$$

- Step 3

$$y = Ae^{5x} + Bxe^{5x}$$

Example 3 Solve:

$$\frac{d^2y}{dx^2} - 4\frac{dy}{dx} + 13y = 0$$

- Step 1

$$r^2 - 4r + 13 = 0$$

- Step 2

$$\Delta < 0, r_1 = 2 + 3i, r_2 = 2 - 3i$$

- Step 3

$$y = e^{2x}(A\cos(3x) + iB\sin(3x))$$

3.2 Method of Solving 2nd Order Non-Homogeneous Differential Equation

The 2nd Order Non-Homogeneous Differential Equation has the form of:

$$\frac{d^2y}{dx^2} + P(x)\frac{dy}{dx} + Q(x)y = f(x)$$

The solution of the 2nd Order Non-Homogeneous Differential Equation has a combination of General solution and Particular solution $y = y_h + y_p$. The General solution is found by finding the solution of the equation in its homogeneous form while the Particular solution is found by finding the solution of the equation in its non-homogeneous.

3.2.1 Method of Undetermined Coefficients

Method

How to use it

- Step 1 : Find y_h from the equation in homogeneous form.
- Step 2 : Propose y_p by guessing the form of solution from the non-homogeneous term. Use the table for help. And determine the constants of the y_p .
- Step 3 : Find $y = y_h + y_p$ and Find remaining constants from initial equation.

Table of solution form

$f(x)$	y_p
1	a
$5x + 7$	$ax + b$
$3x^2 - 2$	$ax^2 + b + c$
$x^3 - x + 1$	$ax^3 + bx^2 + cx + d$
$\sin 4x$	$a\cos 4x + b\sin 4x$
$\cos 4x$	$a\cos 4x + b\sin 4x$
e^{5x}	ae^{5x}
$(9x - 2)e^{5x}$	$(ax + b)e^{5x}$
$x^2 e^{5x}$	$(ax^2 + b + c)e^{5x}$
$e^{3x} \sin 4x$	$ae^{3x} \cos 4x + be^{3x} \sin 4x$
$5x^2 \sin 4x$	$(ax^2 + b + c)\cos 4x + (dx^2 + e + f)\sin 4x$
$xe^{3x} \cos 4x$	$(ax + b)e^{3x} \cos 4x + (cx + d)e^{3x} \sin 4x$

Example Solve:

$$\frac{d^2 y}{dx^2} - y = 2x^2 - x - 3$$

- Step 1

$$r^2 - 1 = 0$$

$$\Delta > 0, r_1 = 1, r_2 = -1$$

$$y_h = Ae^{1x} + Be^{-1x}$$

- Step 2

Let guess the form based on the $2x^2 - x - 3$, because of it is a polynomial let guess $y_p = ax^2 + bx + c$

$$\frac{dy_p}{dx} = 2ax + b$$

$$\frac{d^2 y_p}{dx^2} = 2a$$

3.2. METHOD OF SOLVING 2ND ORDER NON-HOMOGENEOUS DIFFERENTIAL EQUATION

Substitute back to equation

$$2a - (ax^2 + bx + c) = 2x^2 - x - 3$$

$$2a - ax^2 - bx - c = 2x^2 - x - 3$$

$$-ax^2 - bx + 2a - c = 2x^2 - x - 3$$

$$-a = 2$$

$$-b = -1$$

$$2a - c = -3$$

$$\rightarrow a = -2$$

$$\rightarrow b = 1$$

$$\rightarrow c = -1$$

Thus

$$y_p = -2x^2 + x - 1$$

- Step 3

$$y = Ae^{1x} + Be^{-1x} - 2x^2 + x - 1$$

Chapter 4

2nd Order ODE Standard Form

This section, we study on system of 2nd Order ODE with Standard Form Natural Frequency and Damping Ratio.

4.1 Spring Mass Damper Modeling

(Free Body Diagram)

$$\begin{aligned} -kx(t) - b\dot{x}(t) &= m\ddot{x}(t) \\ m\ddot{x}(t) + kx(t) + b\dot{x}(t) &= 0 \\ \ddot{x} + \frac{b}{m}\dot{x} + \frac{k}{m}x(t) &= 0 \end{aligned}$$

Let have the differential model above to look like the General Standard Form of :

$$\boxed{\ddot{x}(t) + 2\zeta\omega_n\dot{x}(t) + \omega_n^2x(t) = 0}$$

Where :

- ζ is damping ratio
- ω_n is natural frequency

Thus, we have :

- $\frac{b}{m} = 2\zeta\omega_n \rightarrow \zeta = \frac{b}{2\sqrt{km}}$
- $\frac{k}{m} = \omega_n^2 \rightarrow \omega_n = \sqrt{\frac{k}{m}}$

Let solve the Standard Form $x(t)$:

$$\ddot{x}(t) + 2\zeta\omega_n\dot{x}(t) + \omega_n^2x(t) = 0$$

Using Laplace Transform :

$$\begin{aligned} s^2X(s) - sx(0) - \dot{x}(0) + 2\zeta\omega_n(sX(s) - x(0)) + \omega_n^2X(s) &= 0 \\ s^2X(s) - sx_0 - \dot{x}_0 + 2\zeta\omega_n(sX(s) - x_0) + \omega_n^2X(s) &= 0 \end{aligned}$$

$$X(s) = \frac{sx_0 + \dot{x}_0 + 2\zeta\omega_n x_0}{s^2 + 2\zeta\omega_n s + \omega_n^2}$$

Let Find the root of the Denominator of $X(s)$. From solving the 2nd order quadratic formula, we have the root :

$$s_{1,2} = \frac{-2\zeta\omega_n \pm \sqrt{(2\zeta\omega_n)^2 - 4\omega_n^2}}{2} = -\zeta\omega_n \pm \omega_n\sqrt{\zeta^2 - 1}$$

From the root, we can see that there are 3 cases:

- Distinct Real Root
- Double Real Root
- Complex Root

4.1.1 Distinct Real Roots

To have the Distinct Real Root Case, We need:

$$\begin{aligned} (2\zeta\omega_n)^2 - 4\omega_n^2 &> 0 \\ 4\zeta^2\omega_n^2 - 4\omega_n^2 &> 0 \\ 4\omega_n^2(\zeta^2 - 1) &> 0 \\ (\zeta^2 - 1) &> 0 \\ \zeta^2 &> 1 \\ \zeta &> 1 \end{aligned}$$

We get Over-damped Case from the damping ratio of $\boxed{\zeta > 1}$

4.1.2 Double Real Root

To have the Double Real Root Case, We need:

$$\begin{aligned} (2\zeta\omega_n)^2 - 4\omega_n^2 &= 0 \\ 4\zeta^2\omega_n^2 - 4\omega_n^2 &= 0 \\ 4\omega_n^2(\zeta^2 - 1) &= 0 \\ (\zeta^2 - 1) &= 0 \\ \zeta^2 &= 1 \\ \zeta &= 1 \end{aligned}$$

We get Critically damped Case from the damping ratio of $\boxed{\zeta = 1}$. From the mathematical perspective, the damping ratio is unity (1) mean Critically damped. Where some people from control perspective prefer the damping ratio of $\frac{1}{\sqrt{2}}$ to be Critically damped.

4.1.3 Complex Root

To have the Complex Root Case, We need:

$$\begin{aligned}(2\zeta\omega_n)^2 - 4\omega_n^2 &< 0 \\ 4\zeta^2\omega_n^2 - 4\omega_n^2 &< 0 \\ 4\omega_n^2(\zeta^2 - 1) &< 0 \\ (\zeta^2 - 1) &< 0 \\ \zeta^2 &< 1 \\ \zeta &< 1\end{aligned}$$

4.2 Discussion of Each Cases

4.2.1 Over-damped Case ($\zeta > 1$)

Above equation can be written as:

$$X(s) = \frac{sx_0 + \dot{x}_0 + 2\zeta\omega_n x_0}{s^2 + 2\zeta\omega_n s + \omega_n^2} = \frac{a_1}{s + r_1} + \frac{a_2}{s + r_2}$$

After using Partial Fraction Decomposition, we get:

$$\begin{aligned}a_1 &= \frac{-\dot{x}_0 + x_0(-\zeta\omega_n + \sqrt{(\zeta^2 - 1)\omega_n^2})}{2\sqrt{(\zeta^2 - 1)\omega_n^2}} \\ a_2 &= \frac{\dot{x}_0 + x_0(\zeta\omega_n + \sqrt{(\zeta^2 - 1)\omega_n^2})}{2\sqrt{(\zeta^2 - 1)\omega_n^2}}\end{aligned}$$

Thus the solution of differential equation $\ddot{x}(t) + 2\zeta\omega_n\dot{x}(t) + \omega_n^2x(t) = 0$ where $x(0) = x_0, \dot{x}(0) = \dot{x}_0$ is :

$$x(t) = a_1e^{r_1t} + a_2e^{r_2t}$$

Where:

$$\begin{aligned}a_1 &= \frac{-\dot{x}_0 + x_0(-\zeta\omega_n + \sqrt{(\zeta^2 - 1)\omega_n^2})}{2\sqrt{(\zeta^2 - 1)\omega_n^2}} \\ a_2 &= \frac{\dot{x}_0 + x_0(\zeta\omega_n + \sqrt{(\zeta^2 - 1)\omega_n^2})}{2\sqrt{(\zeta^2 - 1)\omega_n^2}} \\ r_1, r_2 &= -\zeta\omega_n \pm \omega_n\sqrt{\zeta^2 - 1}\end{aligned}$$

4.2.2 Critically damped Case ($\zeta = 1$)

We have the root : $r_1, r_2 = -\zeta\omega_n \pm \omega_n\sqrt{\zeta^2 - 1}$

By substitute $\zeta = 1$, we get the root :

$$r_1, r_2 = -\omega_n$$

Above equation can be written as:

$$X(s) = \frac{sx_0 + \dot{x}_0 + 2\zeta\omega_n x_0}{s^2 + 2\zeta\omega_n s + \omega_n^2} = \frac{a_1}{s + \omega_n} + \frac{a_2}{(s + \omega_n)^2}$$

After using Partial Fraction Decomposition, we get:

$$a_1 = x_0$$

$$a_2 = \dot{x}_0 + x_0\omega_n$$

Thus the solution of differential equation $\ddot{x}(t) + 2\zeta\omega_n\dot{x}(t) + \omega_n^2x(t) = 0$ where $x(0) = x_0, \dot{x}(0) = \dot{x}_0$ is :

$$x(t) = x_0e^{-\omega_n t} + te^{-\omega_n t}(\dot{x}_0 + x_0\omega_n)$$

Where:

$$a_1 = x_0$$

$$a_2 = \dot{x}_0 + x_0\omega_n$$

4.2.3 Under damped Case ($\zeta < 1$)

We have the root : $r_1, r_2 = -\zeta\omega_n \pm \omega_n\sqrt{\zeta^2 - 1}$

By modify the square root part, we get :

$$\begin{aligned} r_1, r_2 &= -\zeta\omega_n \pm \omega_n\sqrt{-1(1 - \zeta^2)} \\ &= -\zeta\omega_n \pm \omega_n\sqrt{(1 - \zeta^2)}\sqrt{-1} \\ &= -\zeta\omega_n \pm \omega_n\sqrt{(1 - \zeta^2)}i \end{aligned}$$

Let:

$$\sigma = \zeta\omega_n$$

$$\omega_d = \omega_n\sqrt{(1 - \zeta^2)}$$

We can write the root as :

$$r_1, r_2 = -\sigma \pm \omega_d i$$

Rewrite the root in form of :

$$s^2 + 2\zeta\omega_n s + \omega_n^2 = (s + \alpha)^2 + \omega_n^2$$

We get :

$$\alpha = \zeta\omega_n$$

$$\omega = \sqrt{(1 - \zeta^2)}\omega_n$$

Above equation can be written as:

$$X(s) = \frac{sx_0 + \dot{x}_0 + 2\zeta\omega_n x_0}{s^2 + 2\zeta\omega_n s + \omega_n^2} = \frac{sx_0 + \dot{x}_0 + 2\zeta\omega_n x_0}{(s + \alpha)^2 + \omega_n^2}$$

After using Partial Fraction Decomposition, The solution of differential equation $\ddot{x}(t) + 2\zeta\omega_n\dot{x}(t) + \omega_n^2x(t) = 0$ where $x(0) = x_0, \dot{x}(0) = \dot{x}_0$ is :

$$x(t) = a\cos(\omega t) + b\sin(\omega t)$$

Where:

$$\begin{aligned}
 a &= x_0 e^{-\alpha t} \\
 b &= \frac{\dot{x}_0 + x_0 \zeta \omega_n}{\omega} e^{-\alpha t} \\
 \alpha &= \zeta \omega_n \\
 \omega &= \sqrt{(1 - \zeta^2) \omega_n^2}
 \end{aligned}$$

Or in simple form of :

$$x(t) = A e^{-\zeta \omega_n t} \cos(\omega_d t - \phi)$$

Where:

$$\begin{aligned}
 A &= \sqrt{x_0^2 + \frac{(\dot{x}_0 + x_0 \zeta \omega_n)^2}{(1 - \zeta^2) \omega_n^2}} \\
 \omega_d &= \omega_n \sqrt{(1 - \zeta^2)} \\
 \phi &= \text{atan2}\left(\frac{\dot{x}_0 + x_0 \zeta \omega_n}{\omega_n \sqrt{(1 - \zeta^2)}}, x_0\right)
 \end{aligned}$$

Chapter 5

Partial Fraction Decomposition

Usually we have a Function:

$$F(s) = \frac{A(s)}{B(s)}$$

Where:

- $A(s)$ is a polynomial which order is smaller than $B(s)$
- $B(s)$ is a polynomial which order is greater than $A(s)$

To perform the Partial Fraction Decomposition, first we have to get $F(s)$ into the ZPK (Zero, Pole, Gain) format which is:

$$F(s) = \frac{K(s + z_1)(s + z_2)(s + z_3)\dots(s + z_n)}{(s + p_1)(s + p_2)(s + p_3)\dots(s + p_n)}$$

Where:

- z is roots of $A(s)$ that is the zeros of $F(s)$
- p is roots of $B(s)$ that is the poles of $F(s)$

Given denominator of $F(s)$, determine the pole of the polynomial $(s + p_1)\dots(s + p_n)$. From the result we can divide into 3 cases.

5.1 Case 1: Distinct Real Poles

Method

In this case we can propose that the $F(s) = \frac{A(s)}{B(s)}$ can be written into:

$$F(s) = \frac{a_1}{s + p_1} + \frac{a_2}{s + p_2} + \dots + \frac{a_n}{s + p_n}$$

Example

$$F(s) = \frac{s^2 + 8s + 15}{s^3 + 3s^2 + 2s}$$

We can see that Nominator order is greater than Denominator order. And the denominator $s^3 + 3s^2 + 2s$ has the roots $s_1 = 0, s_2 = -2, s_3 = -1 \rightarrow p_1 = 0, p_2 = 2, p_3 = 1$. Thus we have:

$$F(s) = \frac{s^2 + 8s + 15}{s^3 + 3s^2 + 2s} = \frac{s^2 + 8s + 15}{(s + 0)(s + 2)(s + 1)} = \frac{a_1}{s + 0} + \frac{a_2}{s + 2} + \frac{a_3}{s + 1}$$

So we have to find a_1, a_2, a_3 to make it work. We can use 2 methods to do it.

Method 1 Multiplication

$$\frac{s^2 + 8s + 15}{s(s + 2)(s + 1)} = \frac{a_1}{s} + \frac{a_2}{s + 2} + \frac{a_3}{s + 1}$$

Multiply both side in terms of $a_1 (s)$:

$$\begin{aligned} s\left(\frac{s^2 + 8s + 15}{s(s + 2)(s + 1)}\right) &= s\frac{a_1}{s} + s\frac{a_2}{s + 2} + s\frac{a_3}{s + 1} \\ \frac{s^2 + 8s + 15}{(s + 2)(s + 1)} &= a_1 + s\frac{a_2}{s + 2} + s\frac{a_3}{s + 1} \end{aligned}$$

Substitute $s = 0$

$$\begin{aligned} \frac{0 + 0 + 15}{(0 + 2)(0 + 1)} &= a_1 + 0 + 0 \\ a_1 &= \frac{15}{2} \end{aligned}$$

Multiply both side in terms of $a_2 (s + 2)$:

$$\begin{aligned} (s + 2)\left(\frac{s^2 + 8s + 15}{s(s + 2)(s + 1)}\right) &= (s + 2)\frac{a_1}{s} + (s + 2)\frac{a_2}{s + 2} + (s + 2)\frac{a_3}{s + 1} \\ \frac{s^2 + 8s + 15}{(s)(s + 1)} &= (s + 2)\frac{a_1}{s} + a_2 + (s + 2)\frac{a_3}{s + 1} \end{aligned}$$

Substitute $s = -2$

$$\begin{aligned} \frac{(-2)^2 + 8(-2) + 15}{(-2)(-2 + 1)} &= (-2 + 2)\frac{a_1}{-2} + a_2 + (-2 + 2)\frac{a_3}{-2 + 1} \\ \frac{4 - 16 + 15}{2} &= 0 + a_2 + 0 \\ a_2 &= \frac{3}{2} \end{aligned}$$

Multiply both side in terms of $a_3 (s + 1)$:

$$\begin{aligned} (s + 1)\left(\frac{s^2 + 8s + 15}{s(s + 2)(s + 1)}\right) &= (s + 1)\frac{a_1}{s} + (s + 1)\frac{a_2}{s + 2} + (s + 1)\frac{a_3}{s + 1} \\ \frac{s^2 + 8s + 15}{(s)(s + 2)} &= (s + 1)\frac{a_1}{s} + (s + 1)\frac{a_2}{s + 2} + a_3 \end{aligned}$$

Substitute $s = -1$

$$\begin{aligned}\frac{(-1)^2 + 8(-1) + 15}{(-1)(-1 + 2)} &= (-1 + 1)\frac{a_1}{-1} + (-1 + 1)\frac{a_2}{-1 + 2} + a_3 \\ \frac{1 + -8 + 15}{-1} &= 0 + 0 + a_3 \\ a_3 &= -8\end{aligned}$$

So we get:

$$F(s) = \frac{s^2 + 8s + 15}{s^3 + 3s^2 + 2s} = \frac{15}{s} + \frac{\frac{3}{2}}{s + 2} + \frac{-8}{s + 1}$$

Method 2 Coefficient

$$\frac{s^2 + 8s + 15}{s(s + 2)(s + 1)} = \frac{a_1}{s} + \frac{a_2}{s + 2} + \frac{a_3}{s + 1}$$

Get the right-hand side denominator the same as left-hand side.

$$\begin{aligned}\frac{s^2 + 8s + 15}{s(s + 2)(s + 1)} &= \frac{(s + 1)(s + 2)a_1 + s(s + 1)a_2 + s(s + 2)a_3}{s(s + 2)(s + 1)} \\ s^2 + 8s + 15 &= (s + 1)(s + 2)a_1 + s(s + 1)a_2 + s(s + 2)a_3 \\ &= (s^2 + 2s + s + 2)a_1 + (s^2 + s)a_2 + (s^2 + 2s)a_3 \\ &= (s^2 + 3s + 2)a_1 + (s^2 + s)a_2 + (s^2 + 2s)a_3 \\ &= s^2a_1 + 3sa_1 + 2a_1 + s^2a_2 + sa_2 + s^2a_3 + 2sa_3 \\ s^2 + 8s + 15 &= s^2(a_1 + a_2 + a_3) + s(3a_1 + a_2 + 2a_3) + (2a_1) \\ 1 &= a_1 + a_2 + a_3 \\ 8 &= 3a_1 + a_2 + 2a_3 \\ 15 &= 2a_1 \\ a_1 &= \frac{15}{2} \\ a_2 &= \frac{3}{2} \\ a_3 &= -8\end{aligned}$$

So we get:

$$F(s) = \frac{s^2 + 8s + 15}{s^3 + 3s^2 + 2s} = \frac{15}{s} + \frac{\frac{3}{2}}{s + 2} + \frac{-8}{s + 1}$$

5.2 Case 2: Repeated Real Poles

Method

In this case we can propose that the $F(s) = \frac{A(s)}{B(s)}$ can be written into:

$$F(s) = \frac{a_1}{s + p} + \frac{a_2}{(s + p)^2} + \dots + \frac{a_n}{(s + p)^n}$$

Example

$$F(s) = \frac{s^2 + 2s + 3}{(s + 1)^3}$$

The denominator $(s + 1)^3$ has a repeated real pole at $p = -1$. $F(s)$ can be written as:

$$F(s) = \frac{s^2 + 2s + 3}{(s + 1)^3} = \frac{a_1}{s + 1} + \frac{a_2}{(s + 1)^2} + \frac{a_3}{(s + 1)^3}$$

Method 1 Coefficient

Determine a_1, a_2, a_3

$$\frac{s^2 + 2s + 3}{(s + 1)^3} = \frac{(s + 1)^2 a_1}{(s + 1)^2 (s + 1)} + \frac{(s + 1) a_2}{(s + 1)(s + 1)^2} + \frac{a_3}{(s + 1)^3}$$

$$\frac{s^2 + 2s + 3}{(s + 1)^3} = \frac{(s + 1)^2 a_1 + (s + 1) a_2 + a_3}{(s + 1)^3}$$

$$s^2 + 2s + 3 = (s + 1)^2 a_1 + (s + 1) a_2 + a_3$$

$$s^2 + 2s + 3 = s^2 a_1 + 2s a_1 + a_1 + s a_2 + a_2 + a_3$$

$$s^2 + 2s + 3 = s^2 a_1 + s(2a_1 + a_2) + (a_1 + a_2 + a_3)$$

$$1 = a_1$$

$$2 = 2a_1 + a_2$$

$$3 = a_1 + a_2 + a_3$$

$$\rightarrow a_1 = 1$$

$$\rightarrow a_2 = 0$$

$$\rightarrow a_3 = 2$$

Thus we get:

$$F(s) = \frac{s^2 + 2s + 3}{(s + 1)^3} = \frac{1}{s + 1} + \frac{0}{(s + 1)^2} + \frac{2}{(s + 1)^3} = \frac{1}{s + 1} + \frac{2}{(s + 1)^3}$$

Method 2 Derivative

From finding the common denominator above:

$$s^2 + 2s + 3 = (s + 1)^2 a_1 + (s + 1) a_2 + a_3$$

Substitute $s = -1$

$$(-1)^2 + 2(-1) + 3 = (-1 + 1)^2 a_1 + (-1 + 1) a_2 + a_3$$

$$(-1)^2 + 2(-1) + 3 = 0 + 0 + a_3$$

$$a_3 = 2$$

Take derivative of $s^2 + 2s + 3 = (s + 1)^2 a_1 + (s + 1) a_2 + a_3$ both side, we get:

$$2s + 2 = 2(s + 1) a_1 + a_2$$

Substitute $s = -1$

$$2(-1) + 2 = 2(-1 + 1) a_1 + a_2$$

$$2(-1) + 2 = 0 + a_2$$

$$a_2 = 0$$

Take derivative of $2s + 2 = 2(s + 1)a_1 + a_2$ both side, we get:

$$\begin{aligned} 2 &= 2a_1 \\ a_1 &= 1 \end{aligned}$$

Thus we get:

$$F(s) = \frac{s^2 + 2s + 3}{(s + 1)^3} = \frac{1}{s + 1} + \frac{0}{(s + 1)^2} + \frac{2}{(s + 1)^3} = \frac{1}{s + 1} + \frac{2}{(s + 1)^3}$$

5.3 Case 3: Complex Conjugate Poles

Method

In this case we can propose that the $F(s) = \frac{A(s)}{B(s)}$ can be written into:

$$F(s) = \frac{A(s)}{(s + \alpha)^2 + \omega^2}$$

Where from general denominator:

$$s^2 + ds + e = 0$$

$$\alpha = \frac{d}{2}$$

$$\omega = \frac{\sqrt{4e - d^2}}{2}$$

Example

$$F(s) = \frac{s - 1}{s^2 + 2s + 2}$$

From denominator $s^2 + 2s + 2$ in general form $d = 2, e = 2$, we get:

$$\alpha = 1$$

$$\omega = 1$$

Thus:

$$F(s) = \frac{s - 1}{s^2 + 2s + 2} = \frac{s - 1}{(s + 1)^2 + 1^2}$$

5.4 Improper Complex Function

Method

We have a transfer function:

$$F(s) = \frac{A(s)}{B(s)}$$

Where:

- $A(s)$ is a polynomial which order is greater than $B(s)$
- $B(s)$ is a polynomial which order is smaller than $A(s)$

We can use synthetic division to make the $A(s)$ smaller than $B(s)$ (Polynomial Equation division).

Chapter 6

Laplace and Inverse Laplace Transform

Laplace Transform convert a function in time domain into frequency domain in polynomial form. Laplace Transform is used for Analyzing and Solving Ordinary Differential Equation. By using Laplace Transform we can analyze an ODE by just analyze the polynomial equation.

Process

Given an Ordinary Differential Equation and Initial Condition

$$a_2\ddot{x}(t) + a_1\dot{x}(t) + a_0x(t) = b_1\dot{u}(t) + b_0u(t) \quad | \quad x(0) = 0, \dot{x}(0) = 0$$

⇓

Laplace Transform

$$X(s) = \frac{b_1s + b_0}{a_2s^2 + a_1s + a_0} \frac{1}{s}$$

⇓

Partial Fraction Decomposition

$$X(s) = \frac{k_0}{s} + \frac{k_1}{s + p_1} + \frac{k_2}{s + p_2}$$

⇓

Inverse Laplace Transform

$$x(t) = k_0 + k_1e^{-p_1t} + k_2e^{-p_2t}$$

6.1 Laplace Transform

Definition of Laplace Transform: Given a function in time domain, its Laplace Transform is denoted by:

$$F(s) = \mathcal{L}\{f(t)\} = \int_0^{\infty} f(t)e^{-st} dt$$

Where : $s = \sigma + j\omega$

6.1.1 Laplace of Dirac Delta Function

We have a function :

$$\delta(t) = \frac{1}{|a|\sqrt{\pi}} e^{-(t/a)^2}$$

as $a \rightarrow 0$

$$\Delta(s) = 1$$

6.1.2 Laplace of Unit Function

We have a function :

$$u(t) = \begin{cases} 1, & \text{if } t \geq 0 \\ 0, & \text{if } t < 0 \end{cases}$$

We have a Laplace :

$$U(s) = \int_0^{\infty} 1e^{-st} dt = -\frac{1}{s} e^{-st} \Big|_0^{\infty} = -\frac{1}{s} [e^{-\infty} - e^0] = -\frac{1}{s} [0 - 1] = \frac{1}{s}$$

6.1.3 Laplace of $f(t) = e^{-at}$

We have a function :

$$f(t) = e^{-at}$$

We have a Laplace :

$$\begin{aligned} F(s) &= \int_0^{\infty} e^{-at} e^{-st} dt \\ &= \int_0^{\infty} e^{-(s+a)t} dt \\ &= -\frac{1}{s+a} \int_0^{\infty} (-(s+a)t)' e^{-(s+a)t} dt \\ &= -\frac{1}{s+a} [e^{-(s+a)t}]_0^{\infty} \\ &= -\frac{1}{s+a} [e^{-\infty} - e^0] \\ F(s) &= \frac{1}{s+a} \end{aligned}$$

6.1.4 Laplace of $f(t) = t$

We have a function :

$$f(t) = t$$

We have a Laplace :

$$F(s) = \int_0^{\infty} te^{-st} dt$$

Let :

$$\begin{aligned} u = t &\rightarrow du = dt \\ dv = e^{-st} dt &\rightarrow v = \int e^{-st} dt = -\frac{1}{s} e^{-st} \end{aligned}$$

$$\begin{aligned}
F(s) &= uv - \int vdu \\
&= (t)\left(-\frac{1}{s}e^{-st}\right) - \int -\frac{1}{s}e^{-st} dt \\
&= -\frac{t}{s}e^{-st} + \frac{1}{s} \int e^{-st} dt \\
&= -\frac{t}{s}e^{-st} - \frac{1}{s^2}e^{-st} \\
&= -\left(\frac{t}{s} + \frac{1}{s^2}\right)e^{-st} \\
&= -\left(\frac{st+1}{s^2}\right)e^{-st} \Big|_0^\infty \\
&= \frac{1}{s^2}
\end{aligned}$$

6.1.5 Laplace of Integral of a Function

We have an integral of a function:

$$f(t) = \int_0^t f(\tau) d\tau$$

We have a Laplace:

$$\begin{aligned}
F(s) &= \int_0^\infty \left(\int_0^t f(\tau) d\tau\right) e^{-st} dt \\
&= \int_0^t f(\tau) d\tau \left(-\frac{1}{s}\right) e^{-st} \Big|_0^\infty + \int_0^\infty \frac{1}{s} e^{-st} f(t) dt \\
&= \frac{1}{s} \int_0^\infty f(t) e^{-st} dt
\end{aligned}$$

6.1.6 Laplace of Derivative of a Function

We have an integral of a function:

$$f(t) = \frac{df(t)}{dt}$$

We have a Laplace:

$$\begin{aligned}
F(s) &= \int_0^\infty \frac{df(t)}{dt} e^{-st} dt \\
&= e^{-st} f(t) \Big|_0^\infty + \int_0^\infty f(t) s e^{-st} dt \\
&= -f(0) + s \int_0^\infty f(t) e^{-st} dt \\
\mathcal{L}\left\{\frac{df(t)}{dt}\right\} &= s\mathcal{L}\{f(t)\} - f(0)
\end{aligned}$$

6.1.7 Final Value Theorem

FVT is used to relate the steady state behavior of $f(t)$ to the behavior $sF(s)$. If a function has a Laplace transform, then:

$$\lim_{t \rightarrow \infty} f(t) = \lim_{s \rightarrow 0} sF(s)$$

Example 1 We have a system

$$\Omega(s) = \frac{K}{s(\tau s + 1)}$$

To find the steady state value of $\omega(t)$, we get:

$$\omega_{ss} = \lim_{s \rightarrow 0} s \frac{K}{s(\tau s + 1)} = K$$

Example 2 We have a system

$$\begin{aligned} \dot{\omega}(t) + a\omega(t) &= bu(t) \\ s\Omega(s) + a\Omega(s) &= bU(s) \\ \Omega(s)(s + a) &= bU(s) \\ \Omega(s) &= \frac{b}{(s + a)}U(s) \end{aligned}$$

Case 1 : We want to study when $u(t) = V_0$ is step function, thus $U(s) = \frac{V_0}{s}$, we get a system:

$$\Omega(s) = \frac{V_0 b}{s(s + a)}$$

- Check if the poles of the system is on the left-half plane

By finding the roots of denominator of the system $s\Omega(s) = \frac{sV_0 b}{s(s+a)} = \frac{V_0 b}{(s+a)}$. We see the root is $s = -a$ where a is positive, thus the pole of the system in on the left-half place. Finding the steady state of the system:

$$\omega_{ss} = \lim_{s \rightarrow 0} s\Omega(s) = \lim_{s \rightarrow 0} s \frac{V_0 b}{s(s + a)} = \lim_{s \rightarrow 0} \frac{V_0 b}{(s + a)} = \frac{V_0 b}{a}$$

Case 2 : We want to study when $u(t) = t$ is ramp function, thus $U(s) = \frac{1}{s^2}$, we get a system:

$$\Omega(s) = \frac{b}{s^2(s + a)}$$

- Check if the poles of the system is on the left-half plane

By finding the roots of denominator of the system $s\Omega(s) = s \frac{b}{s^2(s+a)} = \frac{b}{s(s+a)}$. We see the root is $s = -a$ and $s = 0$. The root $s = 0$ is exactly on the imaginary axis, thus the pole of the system in not on the left-half place. Thus the system will not come to rest at the final value.

6.2 Inverse Laplace Transform

We want to inverse the Laplace Transform from frequency domain back to time domain.

$$f(t) = \mathcal{L}^{-1}[F(s)] = \oint_{\gamma-iT}^{\gamma+iT} e^{st} F(s) ds$$

From the inverse Laplace Transform from definition, it is very hard. We want to manipulate the Laplace Transform into an easier and recognizable form to easily inverse it.

6.2.1 Case 1: Distinct Real Poles

Example

$$\begin{aligned} F(s) &= \frac{s^2 + 8s + 15}{s^3 + 3s^2 + 2s} = \frac{7.5}{s} + \frac{-8}{s+1} + \frac{1.5}{s+2} \\ \mathcal{L}^{-1}[F(s)] &= \mathcal{L}^{-1}\left[\frac{7.5}{s}\right] + \mathcal{L}^{-1}\left[\frac{-8}{s+1}\right] + \mathcal{L}^{-1}\left[\frac{1.5}{s+2}\right] \\ &= 7.5\mathcal{L}^{-1}\left[\frac{1}{s}\right] - 8\mathcal{L}^{-1}\left[\frac{1}{s+1}\right] + 1.5\mathcal{L}^{-1}\left[\frac{1}{s+2}\right] \\ f(t) &= 7.5 \cdot 1(t) - 8e^{-1t} + 1.5e^{-2t} \end{aligned}$$

6.2.2 Case 2: Repeated Real Poles

Example

$$\begin{aligned} F(s) &= \frac{s^2 + 2s + 3}{(s+1)^3} = \frac{1}{s+1} + \frac{2}{(s+1)^3} \\ \mathcal{L}^{-1}[F(s)] &= \mathcal{L}^{-1}\left[\frac{1}{s+1}\right] + \mathcal{L}^{-1}\left[\frac{2}{(s+1)^3}\right] \\ &= \mathcal{L}^{-1}\left[\frac{1}{s+1}\right] + 2\mathcal{L}^{-1}\left[\frac{1}{(s+1)^3}\right] \\ &= e^{-1t} + 2\left(\frac{1}{(3-1)!}t^{3-1}e^{-1t}\right) \\ f(t) &= e^{-1t} + t^2e^{-t} \end{aligned}$$

6.2.3 Case 3: Complex Conjugate Poles

Example

$$\begin{aligned} F(s) &= \frac{s-1}{s^2 + 2s + 2} = \frac{s-1}{(s+1)^2 + 1^2} \\ \mathcal{L}^{-1}[F(s)] &= \mathcal{L}^{-1}\left[\frac{s-1}{(s+1)^2 + 1^2}\right] = \mathcal{L}^{-1}\left[\frac{s-1+2-2}{(s+1)^2 + 1^2}\right] = \mathcal{L}^{-1}\left[\frac{s+1-2}{(s+1)^2 + 1^2}\right] \\ &= \mathcal{L}^{-1}\left[\frac{s+1}{(s+1)^2 + 1^2}\right] + \mathcal{L}^{-1}\left[\frac{-2}{(s+1)^2 + 1^2}\right] \\ f(t) &= e^{-t}\cos(t) - 2e^{-t}\sin(t) \end{aligned}$$

6.3 Poles Location and Time Domain Response

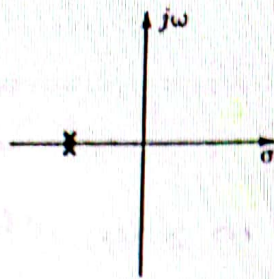
2. Double poles at $s = -a$ 

Stable

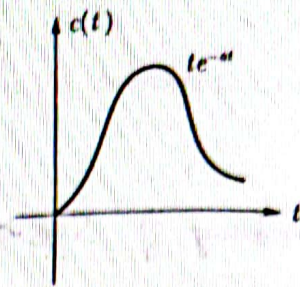
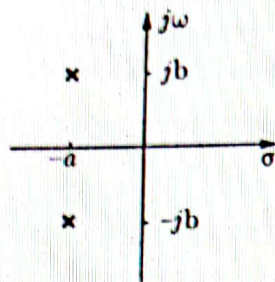
3. Complex conjugate poles at $s = -a \pm jb$ 

Stable

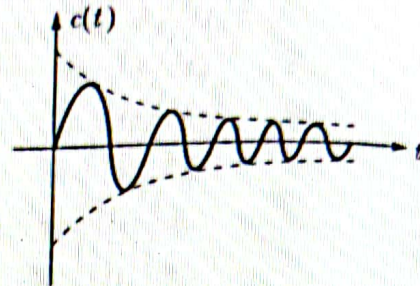
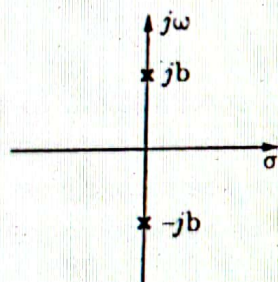
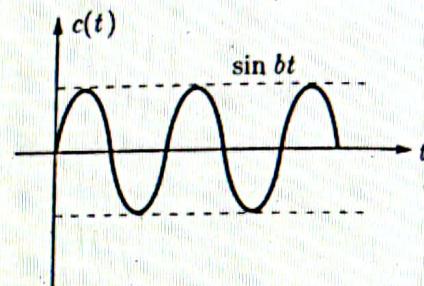
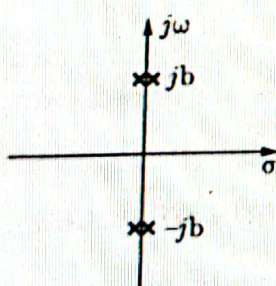
4. Complex conjugate poles at $s = \pm jb$ Marginally
stable5. Double complex conjugate poles at $s = \pm jb$ 

Unstable

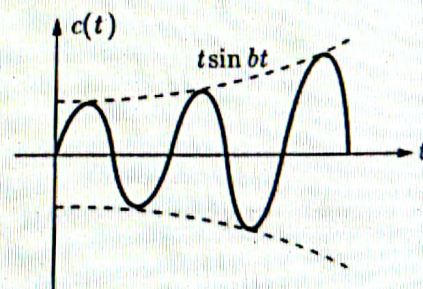
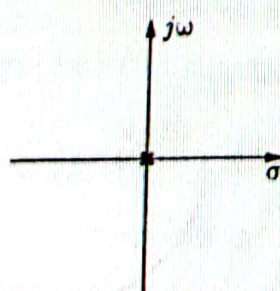
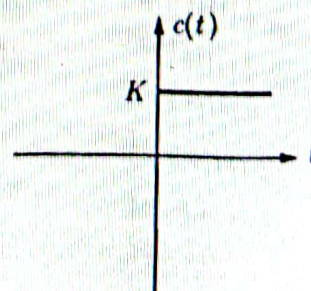
6. Pole at $s = 0$ Marginally
stable

7. Double poles at $s = 0$

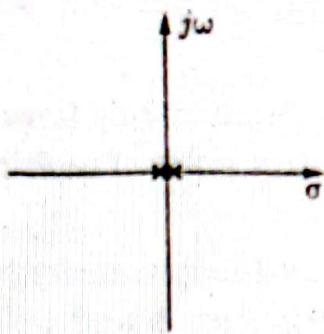

Unstable

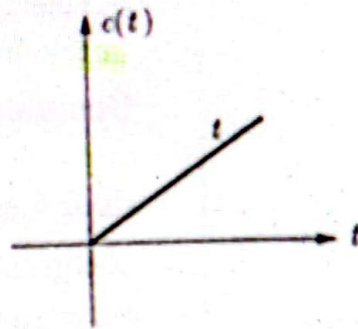

8. Pole at $s = a$

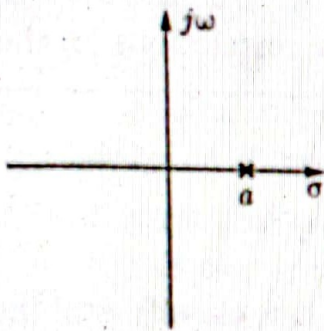

Unstable

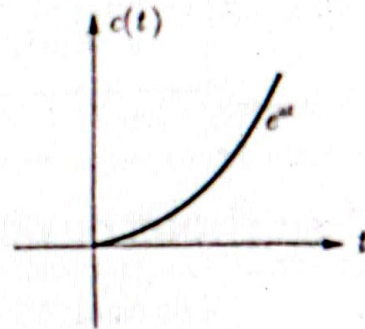

9. Double poles at $s = a$

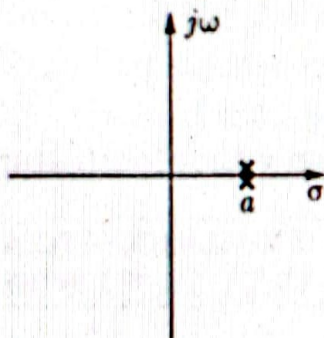

Unstable

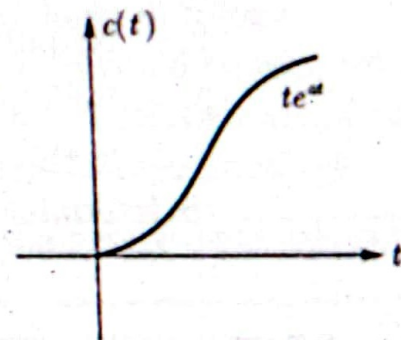

10. Complex conjugate poles at $s = a \pm jb$

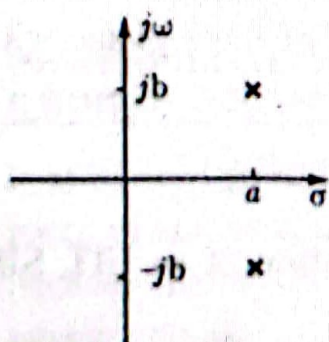

Unstable

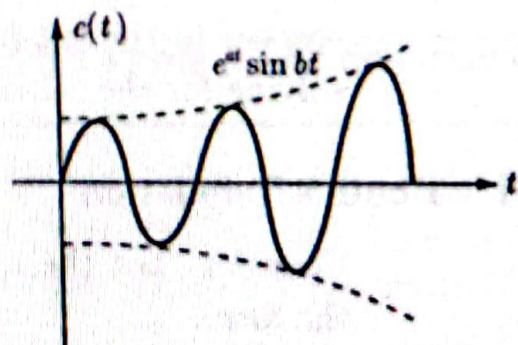

Chapter 7

State Space Representation

Linear State Space Form

$$\dot{x} = A(t)x + Bu(t)$$

Non-Linear State Space Form

$$\dot{x} = f(t, x, u)$$

7.1 Forming State Space

Process

- Step 1 : Obtain Equation of Motion.
- Step 2 : Choose State Variables [ex: position, velocity ...].
- Step 3 : Take Derivative of State Vector.
- Step 4 : Write in State-Space form
- Step 5 : Write Output Equation.

Example 1 Obtain S.S from system below

- Step 1 : Obtain Equation of Motion.

$$\ddot{y} + 4\dot{y} + 3y = 3u$$

- Step 2 : Choose State Variables. We would like to know y and \dot{y} . Thus, Let Choose:

$$X_1 = y$$

$$X_2 = \dot{y}$$

- Step 3 : Take Derivative of State Vector.

$$X_1 = y \Rightarrow \dot{X}_1 = \dot{y}$$

$$X_2 = \dot{y} \Rightarrow \dot{X}_2 = \ddot{y} = 3u - 4\dot{y} - 3y$$

$$\begin{bmatrix} \dot{X}_1 \\ \dot{X}_2 \end{bmatrix} = \begin{bmatrix} \dot{y} \\ 3u - 4\dot{y} - 3y \end{bmatrix}$$

- Step 4 : Write in State-Space form.

$$\dot{X} = \begin{bmatrix} \dot{X}_1 \\ \dot{X}_2 \end{bmatrix} = \begin{bmatrix} 0 & 1 \\ -3 & -4 \end{bmatrix} \begin{bmatrix} X_1 \\ X_2 \end{bmatrix} + \begin{bmatrix} 0 \\ 3 \end{bmatrix} u$$

- Step 5 : Write Output Equation. We choose $y = y_{one}$ because we only interest in displacement only X_1 , if we are interested in velocity X_2 as well we choose $y = y_{two}$.

$$y_{one} = \begin{bmatrix} 1 & 0 \end{bmatrix} \begin{bmatrix} X_1 \\ X_2 \end{bmatrix} \text{ or } y_{two} = \begin{bmatrix} 1 & 0 \\ 0 & 1 \end{bmatrix} \begin{bmatrix} X_1 \\ X_2 \end{bmatrix}$$

Example 2 Obtain S.S from system of mass, spring, damper

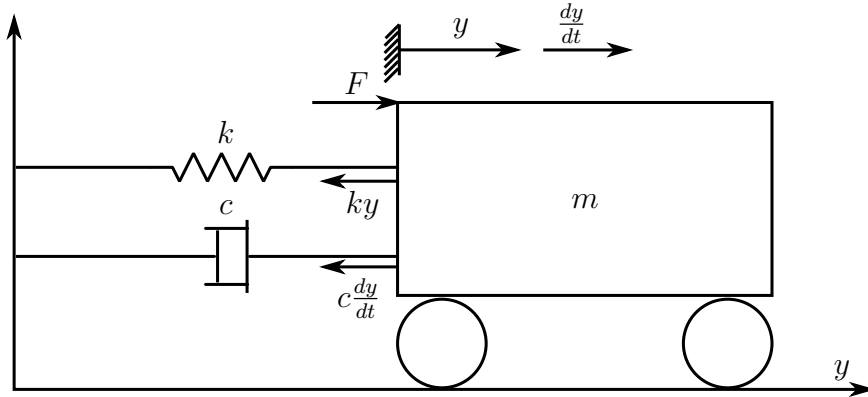

- Step 1 : Obtain Equation of Motion. From the 2nd law of Newton:

$$\begin{aligned} \sum \vec{F} &= m\vec{a} \\ F - ky - c\dot{y} &= m\ddot{y} \\ m\ddot{y} + c\dot{y} + ky &= F \\ \ddot{y} + \frac{c}{m}\dot{y} + \frac{k}{m}y &= \frac{F}{m} \end{aligned}$$

- Step 2 : Choose State Variables. We would like to know y and \dot{y} . Thus, Let Choose:

$$\begin{aligned} X_1 &= y \\ X_2 &= \dot{y} \end{aligned}$$

- Step 3 : Take Derivative of State Vector.

$$\begin{aligned} X_1 = y &\Rightarrow \dot{X}_1 = \dot{y} \\ X_2 = \dot{y} &\Rightarrow \dot{X}_2 = \ddot{y} = \frac{F}{m} - \frac{c}{m}\dot{y} - \frac{k}{m}y \\ \begin{bmatrix} \dot{X}_1 \\ \dot{X}_2 \end{bmatrix} &= \begin{bmatrix} \dot{y} \\ \frac{F}{m} - \frac{c}{m}\dot{y} - \frac{k}{m}y \end{bmatrix} \end{aligned}$$

- Step 4 : Write in State-Space form.

$$\dot{X} = \begin{bmatrix} \dot{X}_1 \\ \dot{X}_2 \end{bmatrix} = \begin{bmatrix} 0 & 1 \\ -\frac{k}{m} & -\frac{c}{m} \end{bmatrix} \begin{bmatrix} X_1 \\ X_2 \end{bmatrix} + \begin{bmatrix} 0 \\ \frac{1}{m} \end{bmatrix} F$$

- Step 5 : Write Output Equation.

$$y = \begin{bmatrix} 1 & 0 \end{bmatrix} \begin{bmatrix} X_1 \\ X_2 \end{bmatrix}$$

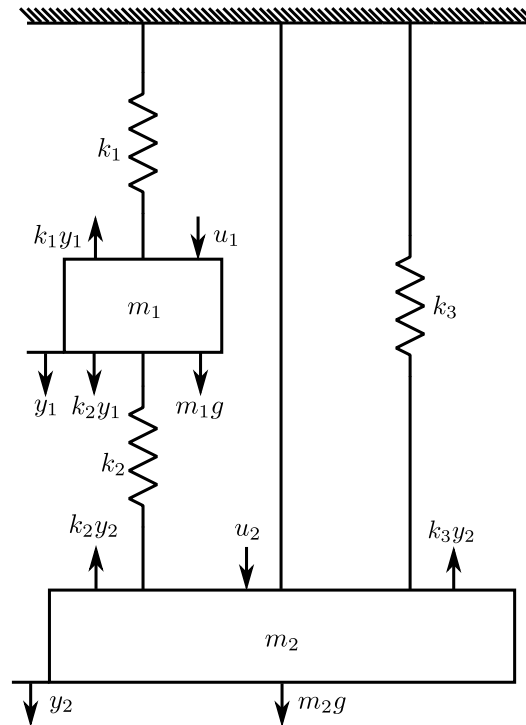

Example 3 Obtain S.S from system of mass, spring with 2 vertical mass

- Step 1 : Obtain Equation of Motion. From the 2nd law of Newton:

$$\sum \vec{F} = m\vec{a}$$

$$\text{Mass 1: } -k_1y_1 + k_2y_1 + u_1 + k_2y_2 = m_1\ddot{y}_1$$

$$\text{Mass 2: } -k_3y_2 - k_2y_2 + u_2 + k_2y_1 = m_2\ddot{y}_2$$

- Step 2 : Choose State Variables. We would like to know y and \dot{y} . Thus, Let Choose:

$$X_1 = y_1$$

$$X_2 = \dot{y}_1$$

$$X_3 = y_2$$

$$X_4 = \dot{y}_2$$

- Step 3 : Take Derivative of State Vector.

$$X_1 = y_1 \Rightarrow \dot{X}_1 = \dot{y}_1$$

$$X_2 = \dot{y}_1 \Rightarrow \dot{X}_2 = \ddot{y}_1 = -\frac{k_1}{m_1}y_1 + \frac{k_2}{m_1}y_1 + \frac{1}{m_1}u_1 + \frac{k_2}{m_1}y_2 = \frac{k_2 - k_1}{m_1}y_1 + \frac{1}{m_1}u_1 + \frac{k_2}{m_1}y_2$$

$$X_3 = y_2 \Rightarrow \dot{X}_3 = \dot{y}_2$$

$$X_4 = \dot{y}_2 \Rightarrow \dot{X}_4 = \ddot{y}_2 = -\frac{k_3}{m_2}y_2 - \frac{k_2}{m_2}y_2 + \frac{1}{m_2}u_2 + \frac{k_2}{m_2}y_1 = \frac{-k_3 - k_2}{m_2}y_2 + \frac{1}{m_2}u_2 + \frac{k_2}{m_2}y_1$$

$$\begin{bmatrix} \dot{X}_1 \\ \dot{X}_2 \\ \dot{X}_3 \\ \dot{X}_4 \end{bmatrix} = \begin{bmatrix} \dot{y}_1 \\ \frac{k_2 - k_1}{m_1}y_1 + \frac{1}{m_1}u_1 + \frac{k_2}{m_1}y_2 \\ \dot{y}_2 \\ \frac{-k_3 - k_2}{m_2}y_2 + \frac{1}{m_2}u_2 + \frac{k_2}{m_2}y_1 \end{bmatrix}$$

- Step 4 : Write in State-Space form.

$$\dot{X} = \begin{bmatrix} \dot{X}_1 \\ \dot{X}_2 \\ \dot{X}_3 \\ \dot{X}_4 \end{bmatrix} = \begin{bmatrix} 0 & 1 & 0 & 0 \\ \frac{k_2-k_1}{m_1} & 0 & \frac{k_2}{m_1} & 0 \\ 0 & 0 & 0 & 1 \\ \frac{k_2}{m_2} & 0 & \frac{-k_3-k_2}{m_2} & 0 \end{bmatrix} \begin{bmatrix} X_1 \\ X_2 \\ X_3 \\ X_4 \end{bmatrix} + \begin{bmatrix} 0 & 0 \\ \frac{1}{m_1} & 0 \\ 0 & 0 \\ 0 & \frac{1}{m_2} \end{bmatrix} \begin{bmatrix} u_1 \\ u_2 \end{bmatrix}$$

- Step 5 : Write Output Equation.

$$y = \begin{bmatrix} 1 & 0 & 0 & 0 \\ 0 & 0 & 1 & 0 \end{bmatrix} \begin{bmatrix} X_1 \\ X_2 \\ X_3 \\ X_4 \end{bmatrix}$$

Example 4 Solve system of single mass and spring and force using Matlab.

MATLAB Numerical Method using ode45(Runge Kutta)

```

1 [t,x] = ode45(@f,tspan,x_0)
2 t = time
3 x = state vector
4 ode45 = solver
5 f = function
6 tspan = t_0 -> t_f
7 x_0 = initial condition
8
9
10 Example:
11
12 tspan = [0,10];
13 x_0 = [0,0];
14
15 function dx = model(t,x)
16 % dx = Ax+Bu
17 k = 0.01;m=1;u=2;
18 A = [0 1;-k/m 0];
19 B = [0;1/m];
20 dx = A*x + B*u;
21
22 [t,x] = ode45(@model,tspan,x_0);
23 plot(t,x(:,1))
24 hold on
25 plot(t,x(:,2))
26 legend('displacement','velocity')

```

Example 5 Obtain S.S from system of mass, spring, damper with 2 horizontal mass
Equation of Motion

$$\sum \vec{F} = m\vec{a}$$

$$\text{Mass 1: } m_1\ddot{p}(t) + b_1\dot{p}(t) + k_1p(t) = u(t) + k_1q(t) + b_1\dot{q}(t)$$

$$\text{Mass 2: } m_2\ddot{q}(t) + (k_1 + k_2)q(t) + (b_1 + b_2)\dot{q}(t) = k_1p(t) + b_1\dot{p}(t)$$

$$\ddot{p}(t) = \frac{1}{m_1}u(t) + \frac{k_1}{m_1}q(t) + \frac{b_1}{m_1}\dot{q}(t) - \frac{b_1}{m_1}\dot{p}(t) - \frac{k_1}{m_1}p(t)$$

$$\ddot{q}(t) = \frac{k_1}{m_2}p(t) + \frac{b_1}{m_2}\dot{p}(t) - \frac{(k_1 + k_2)}{m_2}q(t) - \frac{(b_1 + b_2)}{m_2}\dot{q}(t)$$

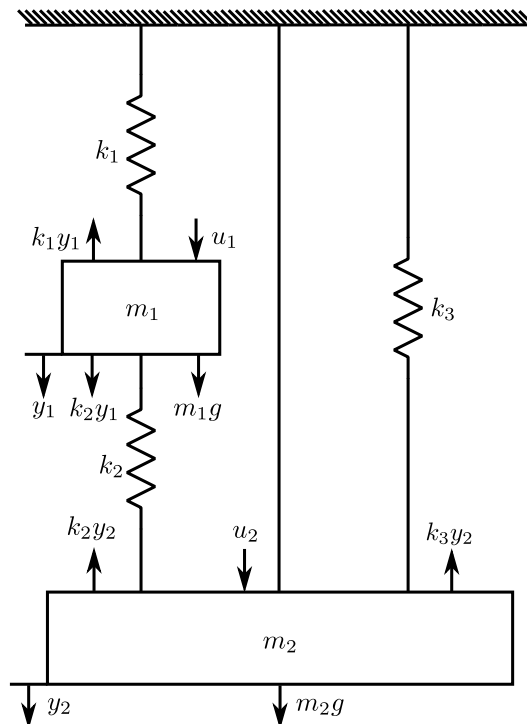

Let:

$$x = \begin{bmatrix} x_1 \\ x_2 \\ x_3 \\ x_4 \end{bmatrix} = \begin{bmatrix} p \\ q \\ \dot{p} \\ \dot{q} \end{bmatrix} \Rightarrow \dot{x} = \begin{bmatrix} \dot{x}_1 \\ \dot{x}_2 \\ \dot{x}_3 \\ \dot{x}_4 \end{bmatrix} = \begin{bmatrix} \dot{p} \\ \dot{q} \\ \ddot{p} \\ \ddot{q} \end{bmatrix}$$

Thus, we get state space form:

$$\dot{x} = \begin{bmatrix} \dot{x}_1 \\ \dot{x}_2 \\ \dot{x}_3 \\ \dot{x}_4 \end{bmatrix} = \begin{bmatrix} 0 & 0 & 1 & 0 \\ 0 & 0 & 0 & 1 \\ -\frac{k_1}{m_1} & \frac{k_1}{m_1} & -\frac{b_1}{m_1} & \frac{b_1}{m_1} \\ \frac{k_1}{m_2} & -\frac{(k_1+k_2)}{m_2} & \frac{b_1}{m_2} & -\frac{(b_1+b_2)}{m_2} \end{bmatrix} \begin{bmatrix} x_1 \\ x_2 \\ x_3 \\ x_4 \end{bmatrix} + \begin{bmatrix} 0 \\ 0 \\ \frac{1}{m_1} \\ 0 \end{bmatrix} u(t)$$

$$y = [1 \quad 0 \quad 0 \quad 0] \begin{bmatrix} x_1 \\ x_2 \\ x_3 \\ x_4 \end{bmatrix}$$

7.2 State Space of Scalar Differential Equation System

7.2.1 Case 1

Consider equation below:

$$y^{(n)} + a_1 y^{(n-1)} + \dots + a_{n-1} y' + a_n y = u \leftarrow \text{Input has not derivative}$$

Let:

$$x = \begin{bmatrix} x_1 \\ x_2 \\ \vdots \\ x_{n-1} \\ x_n \end{bmatrix} = \begin{bmatrix} y \\ y' \\ \vdots \\ y^{n-1} \\ y^n \end{bmatrix}$$

Thus

$$\dot{x} = \begin{bmatrix} \dot{x}_1 \\ \dot{x}_2 \\ \vdots \\ \dot{x}_{n-1} \\ \dot{x}_n \end{bmatrix} = \begin{bmatrix} y' \\ y'' \\ \vdots \\ y^n \\ -a_0x_1 - a_1x_2 \dots - a_nx_n + u \end{bmatrix} = \begin{bmatrix} \dot{x}_2 \\ \dot{x}_3 \\ \vdots \\ \dot{x}_n \\ -a_0x_1 - a_1x_2 \dots - a_nx_n + u \end{bmatrix}$$

Arrange into SS form:

$$\dot{x} = \begin{bmatrix} 0 & 1 & 0 & \dots & 0 \\ 0 & 0 & 1 & \dots & 0 \\ \vdots & \vdots & \vdots & \dots & \vdots \\ -a_n & -a_{n-1} & -a_{n-2} & \dots & -a_1 \end{bmatrix} \begin{bmatrix} x_1 \\ x_2 \\ \vdots \\ x_n \end{bmatrix} + \begin{bmatrix} 0 \\ 0 \\ \vdots \\ 1 \end{bmatrix} u$$

$$y = [1 \quad 0 \quad \dots \quad 0] \begin{bmatrix} x_1 \\ x_2 \\ \vdots \\ x_n \end{bmatrix}$$

We have a corresponding Transfer Function is

$$\frac{Y(s)}{U(s)} = \frac{1}{s^n + a_1s^{n-1} + \dots + a_{n-1}s + a_n}$$

7.2.2 Case 2

Consider equation below:

$$y^{(n)} + a_1y^{(n-1)} + \dots + a_{n-1}y' + a_ny = \beta_0u^n + \beta_1u^{n-1} + \dots + \beta_nu \leftarrow \text{Input has derivative}$$

Let:

$$\begin{aligned} x_1 &= y - \beta_0u \\ x_2 &= y' - \beta_0u' - \beta_1u = x_1' - \beta_1u \\ &\vdots \\ x_n &= y^{n-1} - \beta_0u^{n-1} - \dots - \beta_{n-1}u = x_{n-1}' - \beta_{n-1}u \end{aligned}$$

Where $\beta_0, \beta_1, \dots, \beta_{n-1}$ are determined from:

$$\begin{aligned} \beta_0 &= b_0 \\ \beta_1 &= b_1 - a_1\beta_0 \\ \beta_2 &= b_2 - a_1\beta_1 - a_2\beta_0 \\ &\vdots \end{aligned}$$

Arrange into SS form:

$$\dot{x} = \begin{bmatrix} 0 & 1 & 0 & \dots & 0 \\ 0 & 0 & 1 & \dots & 0 \\ \vdots & \vdots & \vdots & \dots & \vdots \\ -a_n & -a_{n-1} & -a_{n-2} & \dots & -a_1 \end{bmatrix} \begin{bmatrix} x_1 \\ x_2 \\ \vdots \\ x_n \end{bmatrix} + \begin{bmatrix} \beta_1 \\ \beta_2 \\ \vdots \\ \beta_n \end{bmatrix} u$$

$$y = [1 \quad 0 \quad \dots \quad 0] \begin{bmatrix} x_1 \\ x_2 \\ \vdots \\ x_n \end{bmatrix} + \beta_0 u$$

We have a corresponding Transfer Function is

$$\frac{Y(s)}{U(s)} = \frac{b_0 s^n + b_1 s^{n-1} + \dots + b_{n-1} s + b_n}{s^n + a_1 s^{n-1} + \dots + a_{n-1} s + a_n}$$

7.3 Transfer Function to State Space

Example

$$\frac{Y(s)}{U(s)} = \frac{100}{s^4 + 20s^3 + 10s^2 + 7s + 100}$$

$$(s^4 + 20s^3 + 10s^2 + 7s + 100)Y(s) = 100U(s)$$

Taking Inverse Laplace Transform

$$y^{(4)} + 20y^{(3)} + 10y'' + 7y' + 100y = 100u$$

Let:

$$x_1 = y \Rightarrow \dot{x}_1 = y' = x_2$$

$$x_2 = y' \Rightarrow \dot{x}_2 = y'' = x_3$$

$$x_3 = y'' \Rightarrow \dot{x}_3 = y^{(3)} = x_4$$

$$x_4 = y^{(3)} \Rightarrow \dot{x}_4 = y^{(4)} = 100u - 20y^{(3)} - 10y'' - 7y' - 100y$$

State Space form:

$$\dot{x} = \begin{bmatrix} 0 & 1 & 0 & 0 \\ 0 & 0 & 1 & 0 \\ 0 & 0 & 0 & 1 \\ -100 & -7 & -10 & -20 \end{bmatrix} \begin{bmatrix} x_1 \\ x_2 \\ x_3 \\ x_4 \end{bmatrix} + \begin{bmatrix} 0 \\ 0 \\ 0 \\ 100 \end{bmatrix} u$$

$$y = [1 \quad 0 \quad 0 \quad 0] \begin{bmatrix} x_1 \\ x_2 \\ x_3 \\ x_4 \end{bmatrix}$$

7.4 State Space to Transfer Function

We have a Transfer Function:

$$\frac{Y(s)}{U(s)} = G(s)$$

with state space in form of:

$$\begin{aligned}\dot{x} &= Ax + Bu \\ y &= Cx + Du\end{aligned}$$

Let have a Laplace transform of SS:

$$\begin{aligned}sX(s) - x(0) &= AX(s) + BU(s) \\ Y(s) &= CX(s) + DU(s)\end{aligned}$$

Assuming $x(0) = 0IC$, we get:

$$\begin{aligned}sX(s) - AX(s) &= BU(s) \\ (sI - A)X(s) &= BU(s) \\ (sI - A)^{-1}(sI - A)X(s) &= (sI - A)^{-1}BU(s) \\ X(s) &= (sI - A)^{-1}BU(s)\end{aligned}$$

Substitute into $Y(s)$

$$\begin{aligned}Y(s) &= C[(sI - A)^{-1}BU(s)] + DU(s) \\ Y(s) &= C(sI - A)^{-1}BU(s) + DU(s) \\ Y(s) &= [C(sI - A)^{-1}B + D]U(s)\end{aligned}$$

Thus the Transfer function can be found by:

$$G(s) = C(sI - A)^{-1}B + D$$

Example

$$\begin{aligned}\dot{x} &= \begin{bmatrix} 0 & 1 & 0 \\ 0 & 0 & 1 \\ -5 & -25 & -5 \end{bmatrix} \begin{bmatrix} x_1 \\ x_2 \\ x_3 \end{bmatrix} + \begin{bmatrix} 0 \\ 25 \\ -120 \end{bmatrix} u \\ y &= [1 \quad 0 \quad 0] \begin{bmatrix} x_1 \\ x_2 \\ x_3 \end{bmatrix}\end{aligned}$$

$$G(s) = [1 \quad 0 \quad 0] \left[\begin{bmatrix} s & 0 & 0 \\ 0 & s & 0 \\ 0 & 0 & s \end{bmatrix} - \begin{bmatrix} 0 & 1 & 0 \\ 0 & 0 & 1 \\ -5 & -25 & -5 \end{bmatrix} \right]^{-1} \begin{bmatrix} 0 \\ 25 \\ -120 \end{bmatrix} + 0$$

$$G(s) = [1 \quad 0 \quad 0] \begin{bmatrix} s & 1 & 0 \\ 0 & s & 1 \\ -5 & -25 & s+5 \end{bmatrix}^{-1} \begin{bmatrix} 0 \\ 25 \\ -120 \end{bmatrix}$$

$$G(s) = \begin{bmatrix} 1 & 0 & 0 \end{bmatrix} \begin{bmatrix} \frac{(s^2+5s+25)}{(s^3+5s^2+25s-5)} & \frac{(-s-5)}{(s^3+5s^2+25s-5)} & \frac{1}{(s^3+5s^2+25s-5)} \\ \frac{-5}{(s^3+5s^2+25s-5)} & \frac{(s^2+5s)}{(s^3+5s^2+25s-5)} & \frac{-s}{(s^3+5s^2+25s-5)} \\ \frac{5s}{(s^3+5s^2+25s-5)} & \frac{(25s-5)}{(s^3+5s^2+25s-5)} & \frac{s^2}{(s^3+5s^2+25s-5)} \end{bmatrix} \begin{bmatrix} 0 \\ 25 \\ -120 \end{bmatrix}$$

$$G(s) = \begin{bmatrix} 1 & 0 & 0 \end{bmatrix} \begin{bmatrix} \frac{(-25s-245)}{(s^3+5s^2+25s-5)} \\ \frac{(25s^2+245s)}{(s^3+5s^2+25s-5)} \\ \frac{(-120s^2+625s-125)}{(s^3+5s^2+25s-5)} \end{bmatrix}$$

$$G(s) = \frac{(-25s - 245)}{(s^3 + 5s^2 + 25s - 5)}$$

Thus

$$G(s) = \frac{25s + 245}{s^3 + 5s^2 + 25s + 5}$$

Chapter 8

Linear Approximation with Taylor Series

What is a Linear System ? Linear System is a system that comply to 2 rules.

- Superposition (Addition).
- Homogeneous (Multiplication).

8.1 Superposition

Given that we have a function $y = f(x)$.

- If we have a value x_1 substitute to the function we get $y_1 : y_1 = f(x_1)$
- If we have a value x_2 substitute to the function we get $y_2 : y_2 = f(x_2)$.
- If we have a value $x_1 + x_2$ substitute to the function we should get $y_1 + y_2 : y_1 + y_2 = f(x_1 + x_2)$

8.2 Homogeneous

Given that we have a function $y = f(x)$.

- If we have a value αx_1 substitute to the function we get $y_1 : y_1 = f(\alpha x_1)$
- If we have a value x_1 substitute to the function then multiply by α we should get $y_1 = \alpha f(x_1)$

Example Find out if the function is linear : $y = x$

Superposition test $y_1 = x_1, y_2 = x_2$ Add both result together $y_1 + y_2 = x_1 + x_2$
Substitute $x_1 + x_2$ to the function we get $y_1 + y_2$. Thus, $y_1 + y_2 = y_{12}$. TEST PASS.

Homogeneous test Substitute αx we get $y = \alpha x$. Substitute x and multiply by α we get $y = \alpha x$. Thus, $\alpha x = \alpha x$. TEST PASS. Both test is passed and thus the system is linear.

Example Find out if the function is linear : $y = x^2$

Superposition test $y_1 = x_1^2, y_2 = x_2^2$. Add both result together $y_1 + y_2 = x_1^2 + x_2^2$. Substitute $x_1 + x_2$ to the function we get $(x_1 + x_2)^2$. Thus, $y_1 + y_2 \neq y_{1+2}$. TEST FAIL. The test is failed and thus the system is nonlinear.

8.3 Linearization Process

One of the Linearization method is by using Taylor Expansion Series within an operational range for stability.

$$y \approx y(x_0) + \left[\frac{dy}{dx} \Big|_{x_0} \frac{(x - x_0)}{1!} \right] + \left[\frac{d^2y}{dx^2} \Big|_{x_0} \frac{(x - x_0)^2}{2!} \right] + \dots [HigherOrderTerm]$$

Let take a look at the plot:

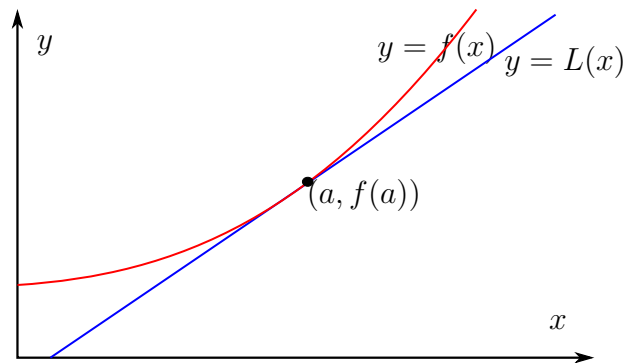

Figure 8.1: Mass spring system

$y = L(x)$ is the linear approximation of $y = f(x)$ and $a = x_0$ is an equilibrium point. We can see that we want to pick an operational range where the function is stable because the $y = L(x)$ is close to $y = f(x)$. As we move a way from the operational range, the approximation is starting to diverge from the real solution.

Example Linearize : $y = x^2$. We have:

$$y \approx y(x_0) + \left[\frac{dy}{dx} \Big|_{x_0} \frac{(x - x_0)}{1!} \right] + \left[\frac{d^2y}{dx^2} \Big|_{x_0} \frac{(x - x_0)^2}{2!} \right] + \dots [HigherOrderTerm]$$

Only consider the first order term and eliminate HOT because in HOT the variable x is subject to power number that will make it nonlinear. We get:

$$y \approx y(x_0) + \left[\frac{dy}{dx} \Big|_{x_0} \frac{(x - x_0)}{1!} \right]$$

We get:

$$\frac{dy}{dx} \Big|_{x_0} = \frac{d(x^2)}{dx} \Big|_{x_0} = 2x \Big|_{x_0} = 2x_0$$

We get:

$$y \approx y(x_0) + \left[2x_0 \frac{(x - x_0)}{1!} \right]$$

$$y \approx y(x_0) + [2x_0(x - x_0)]$$

$$\boxed{y \approx y(x_0) + 2x_0x - 2x_0^2}$$

Let pick an equilibrium point $x_0 = 2$

$$y = 2^2 + 2 \times 2x - 2 \times 2^2$$

$$y = 4 + 4x - 8$$

$$y = 4x - 4$$

Now that we have a original function $y = x^2$ and approximation function at $x_0 = 2$ $y = 4x - 4$. Let compare:

$$x = 2$$

$$\Rightarrow y_{ori} = 2^2 = 4$$

$$\Rightarrow y_{lin} = 4 \times 2 - 4 = 4$$

Both are equal to each other at equilibrium point.

$$x = 3$$

$$\Rightarrow y_{ori} = 3^2 = 9$$

$$\Rightarrow y_{lin} = 4 \times 3 - 4 = 8$$

A way from the equilibrium point, it starts to diverge.

Chapter 9

DC Motor

DC motor is a mechatronic product that consist of two parts: the mechanical part and the electrical part. A typical dc motor used by a robot is constructed by: a dc motor, a wheel encoder (for measuring rotation pulse of motor), and a gear box (for reducing the speed of motor).

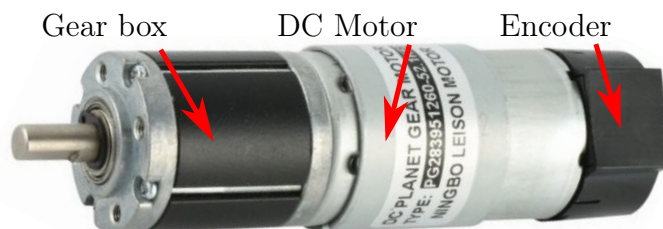

Figure 9.1: Typical DC Motor

9.1 Modelling

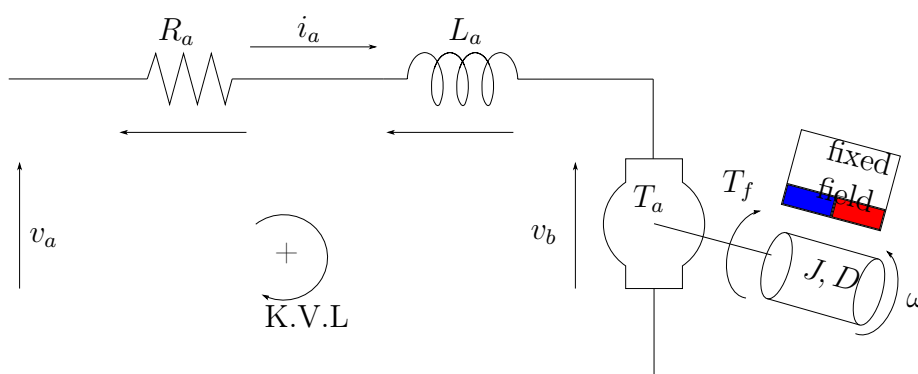

Figure 9.2: dc motor model

9.1.1 Electrical Part

$$v_b(t) = K_b \dot{\theta}(t) = K_b \omega(t) \tag{9.1}$$

Where:

- $v_b(t)$ is voltage at terminal conductor of motor
- K_b is back emf constant
- $\dot{\theta} = \omega$ is angular velocity of motor

$$T_a = K_t i_a(t) \quad (9.2)$$

Where:

- T_a is rotor torque
- K_t is motor torque
- i_a is the current draw by motor

By applying Kirchoff Voltage Law to the circuit loop in Figure 9.2

- $v_a(t)$ is input voltage from power source
- $v_{resistance} = R_a i_a(t)$ is voltage across resistance
- $v_{inductor} = L_a \frac{di_a(t)}{dt}$ is voltage across inductor

$$\begin{aligned} v_a(t) - v_b(t) - R_a i_a(t) - L_a \frac{di_a(t)}{dt} &= 0 \\ \Rightarrow v_a(t) &= v_b(t) + R_a i_a(t) + L_a \frac{di_a(t)}{dt} \end{aligned} \quad (9.3)$$

Substitute Equation 9.1 into Equation 9.3, we get:

$$v_a(t) = K_b \omega(t) + R_a i_a(t) + L_a \frac{di_a(t)}{dt} \quad (9.4)$$

In practical dc motor the L_a is very small ($L_a \approx 0$) and neglectable.

$$\begin{aligned} v_a(t) &= K_b \omega(t) + R_a i_a(t) \\ \Rightarrow \boxed{i_a(t) = \frac{v_a(t) - K_b \omega(t)}{R_a}} \end{aligned} \quad (9.5)$$

9.1.2 Mechanical Part

$$T_a = T_f + J\dot{\omega}(t) \quad (9.6)$$

Where:

- T_f is torque of coulomb friction and viscous friction
- J is moment of inertia

We know that:

$$T_f = T_c \text{sign}[\omega(t)] + D\omega(t) \quad (9.7)$$

Where:

- T_c is coulomb friction torque
- D is coefficient viscous friction

Substitute Equation 9.7 to Equation 9.6, we get:

$$T_a = T_c \text{sign}[\omega(t)] + D\omega(t) + J\dot{\omega}(t)$$

9.1.3 Approximation of coulomb friction to zero $T_c \approx 0$

$$T_a = D\omega(t) + J\dot{\omega}(t) \quad (9.8)$$

From Equation 9.2: $T_a = K_t i_a(t)$ substitute to Equation 9.8:

$$K_t i_a(t) = D\omega(t) + J\dot{\omega}(t)$$

$$\Rightarrow \boxed{i_a(t) = \frac{D\omega(t) + J\dot{\omega}(t)}{K_t}} \quad (9.9)$$

9.1.4 Keep coulomb friction T_c

$$\Rightarrow \boxed{i_a(t) = \frac{T_c \text{sign}[\omega(t)] + D\omega(t) + J\dot{\omega}(t)}{K_t}} \quad (9.10)$$

9.1.5 Electrical and Mechanical combine

9.1.6 Approximation of coulomb friction to zero $T_c \approx 0$

From Equation 9.5 and Equation 9.9: Put it side by side:

$$i_a(t) = i_a(t)$$

$$\frac{v_a(t) - K_b\omega(t)}{R_a} = \frac{D\omega(t) + J\dot{\omega}(t)}{K_t}$$

Get $\dot{\omega}(t)$:

$$\dot{\omega}(t) = \frac{\frac{(v_a(t) - K_b\omega(t))K_t}{R_a} - D\omega(t)}{J}$$

$$\dot{\omega}(t) = \frac{(v_a(t) - K_b\omega(t))K_t}{R_a J} - \frac{D\omega(t)}{J}$$

$$\dot{\omega}(t) = \frac{v_a(t)K_t - K_b K_t \omega(t)}{R_a J} - \frac{D\omega(t)}{J}$$

Separate $\omega(t)$ and $v_a(t)$:

Lumped Parameters without Friction

$$\dot{\omega}(t) = -\left(\frac{K_b K_t + DR_a}{R_a J}\right)\omega(t) + \frac{K_t}{R_a J}v_a(t) \quad (9.11)$$

Let:

- $a = \left(\frac{K_b K_t + DR_a}{R_a J}\right)\omega(t) \quad [1/s]$
- $b = \frac{K_t}{R_a J} \quad [rad/s^2/V]$

We get lumped Parameter in a simplified form as:

$$\Rightarrow \dot{\omega}(t) = -a\omega(t) + bv_a(t) \quad (9.12)$$

9.1.7 Keep coulomb friction T_c

Lumped Parameters with Friction

$$\dot{\omega}(t) = -\left(\frac{K_b K_t + DR_a}{R_a J}\right)\omega(t) + \frac{K_t}{R_a J}v_a(t) - \frac{T_c}{J}sign(\omega(t)) \quad (9.13)$$

Let:

- $a = \left(\frac{K_b K_t + DR_a}{R_a J}\right) \quad [1/s]$
- $b = \frac{K_t}{R_a J} \quad [rad/s^2/V]$
- $c = \frac{T_c}{J} \quad [.]$

We get lumped Parameter in a simplified form as:

$$\Rightarrow \dot{\omega}(t) = -a\omega(t) + bv_a(t) - csign(\omega(t)) \quad (9.14)$$

9.2 Simulation

In general, the equation $\dot{\omega}(t) = -a\omega(t) + bv_a(t) - csign(\omega(t))$ is used to represent all the dc motor in the market. By modifying the parameters a, b, c will result in different dc motor. From equation $\dot{\omega}(t) = -a\omega(t) + bv_a(t) - csign(\omega(t))$

- $\dot{\omega}(t)$ is the angular acceleration of dc motor and is the output of the system
- $\omega(t)$ is the angular velocity of dc motor and is the output of the system
- $v_a(t)$ is the input voltage to dc motor and is the input of the system

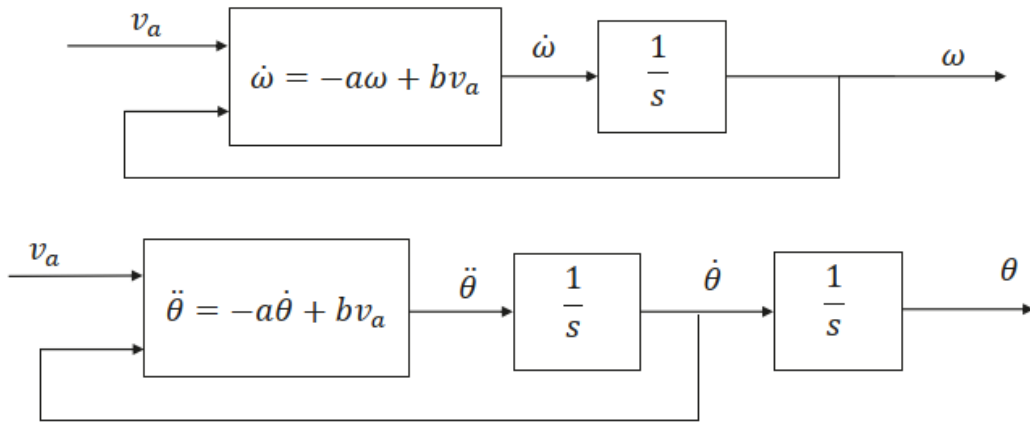

Figure 9.3: Simulation Flow

9.3 DC Motor 2nd Order Model (L_a is not Neglected)

9.3.1 No Friction

From Equation 9.4 and Equation 9.9, we have:

$$v_a(t) = K_b\omega(t) + R_a i_a(t) + L_a \frac{di_a(t)}{dt}$$

$$i_a(t) = \frac{D\omega(t) + J\dot{\omega}(t)}{K_t}$$

$$\begin{aligned} \frac{di_a(t)}{d(t)} &= \frac{d}{dt} \left(\frac{D\omega(t) + J\dot{\omega}(t)}{K_t} \right) \\ &= \frac{1}{K_t} \frac{d}{dt} (D\omega(t) + J\dot{\omega}(t)) \\ &= \frac{1}{K_t} \frac{d}{dt} (D\omega(t)) + \frac{d}{dt} (J\dot{\omega}(t)) \\ &= \frac{1}{K_t} (D\dot{\omega}(t) + J\ddot{\omega}(t)) \end{aligned}$$

We get:

$$v_a(t) = K_b\omega(t) + R_a \frac{D\omega(t) + J\dot{\omega}(t)}{K_t} + L_a \frac{1}{K_t} (D\dot{\omega}(t) + J\ddot{\omega}(t)) \quad (9.15)$$

$$\begin{aligned} K_t v_a(t) &= K_t K_b \omega(t) + R_a (D\omega(t) + J\dot{\omega}(t)) + L_a (D\dot{\omega}(t) + J\ddot{\omega}(t)) \\ K_t v_a(t) &= K_t K_b \omega(t) + R_a D\omega(t) + R_a J\dot{\omega}(t) + L_a D\dot{\omega}(t) + L_a J\ddot{\omega}(t) \\ K_t v_a(t) &= (K_t K_b + R_a D)\omega(t) + (R_a J + L_a D)\dot{\omega}(t) + L_a J\ddot{\omega}(t) \\ L_a J\ddot{\omega}(t) &= -(K_t K_b + R_a D)\omega(t) - (R_a J + L_a D)\dot{\omega}(t) + K_t v_a(t) \end{aligned}$$

Lumped Parameters without Friction 2nd Order

$$\ddot{\omega}(t) = -\frac{R_a J + L_a D}{L_a J} \dot{\omega}(t) - \frac{K_t K_b + R_a D}{L_a J} \omega(t) + \frac{K_t}{L_a J} v_a(t)$$

Let:

$$a = \frac{R_a J + L_a D}{L_a J}, b = \frac{K_t K_b + R_a D}{L_a J}, c = \frac{K_t}{L_a J}$$

We get lumped Parameter in a simplified form as:

$$\Rightarrow \ddot{\omega}(t) = -a\dot{\omega}(t) - b\omega(t) + cv_a(t) \quad (9.16)$$

9.3.2 With Friction

From Equation 9.4 and Equation 9.10, we have:

$$v_a(t) = K_b \omega(t) + R_a i_a(t) + L_a \frac{di_a(t)}{dt}$$

$$i_a(t) = \frac{T_c \text{sign}[\omega(t)] + D\omega(t) + J\dot{\omega}(t)}{K_t}$$

$$\frac{di_a(t)}{dt} = \frac{d}{dt} \left(\frac{T_c \text{sign}[\omega(t)] + D\omega(t) + J\dot{\omega}(t)}{K_t} \right)$$

$$= \frac{1}{K_t} (D\dot{\omega}(t) + J\ddot{\omega}(t)) \leftarrow \text{derivative of sign function is 0}$$

We get:

$$v_a(t) = K_b \omega(t) + R_a \frac{T_c \text{sign}[\omega(t)] + D\omega(t) + J\dot{\omega}(t)}{K_t} + L_a \frac{1}{K_t} (D\dot{\omega}(t) + J\ddot{\omega}(t)) \quad (9.17)$$

$$K_t v_a(t) = K_t K_b \omega(t) + R_a T_c \text{sign}[\omega(t)] + R_a D\omega(t) + R_a J\dot{\omega}(t) + L_a D\dot{\omega}(t) + L_a J\ddot{\omega}(t)$$

Lumped Parameters with Friction 2nd Order

$$\ddot{\omega}(t) = -\frac{R_a J + L_a D}{L_a J} \dot{\omega}(t) - \frac{K_t K_b + R_a D}{L_a J} \omega(t) + \frac{K_t}{L_a J} v_a(t) - \frac{R_a T_c}{L_a J} \text{sign}[\omega(t)]$$

Let:

$$a = \frac{R_a J + L_a D}{L_a J}, b = \frac{K_t K_b + R_a D}{L_a J}, c = \frac{K_t}{L_a J}, d = \frac{R_a T_c}{L_a J}$$

We get lumped Parameter in a simplified form as:

$$\Rightarrow \ddot{\omega}(t) = -a\dot{\omega}(t) - b\omega(t) + cv_a(t) - d\text{sign}(\omega(t)) \quad (9.18)$$

Chapter 10

DC Motor Lamped Parameters Identification

DC Motor is widely used in many applications such as robot, industrial application -etc. It has been produced in great number, some is at high standard with larger documentation and specification while some are inexpensive with little to none of documentation. To be able to use the dc motor efficiently, we must know it mathematical model. In this lesson, we use a variant of a famous algorithm known as Extended Kalman Filter (EKF) and Unscented Kalman Filter (UKF) to estimate the dc motor model.

10.1 DC Motor Stochastic State Space Model

From Lecture 1 : DC Motor, We have a mathematical model to represent the motor: Model with neglect the coulomb friction:

$$\dot{\omega}(t) = -a\omega(t) + bv_a(t)$$

Model with the coulomb friction:

$$\dot{\omega}(t) = -a\omega(t) + bv_a(t) - c\text{sign}(\omega(t))$$

10.1.1 Model with neglect the coulomb friction

From the model:

$$\dot{\omega}(t) = -a\omega(t) + bv_a(t) \tag{10.1}$$

In control system, we have a state space model for a nonlinear model:

$$\dot{x}(t) = f(t, x(t), u(t)) + v_{noise}(t)$$

$$y(t) = h(t, x(t), u(t)) + \omega_{noise}(t)$$

Where:

- $\dot{x}(t)$ is rate of change of state
- $x(t)$ is the current state
- $u(t)$ is the input to the system

- $y(t)$ is the measurement model
- $v_{noise}(t)$ is random process noise
- $\omega_{noise}(t)$ is random measurement noise

From Equation 10.1, Let:

$$\begin{aligned}x_1 &= \omega \\x_2 &= a \\x_3 &= b\end{aligned}\tag{10.2}$$

We get:

$$\begin{aligned}\dot{x}_1 = \dot{\omega} &= -a\omega(t) + bv_a(t) = -x_2x_1 + x_3v_a(t) \\ \dot{x}_2 &= 0 \\ \dot{x}_3 &= 0\end{aligned}\tag{10.3}$$

In continuous nonlinear stochastic system matrix form

$$\begin{aligned}\dot{x}(t) &= \begin{bmatrix} \dot{x}_1 \\ \dot{x}_2 \\ \dot{x}_3 \end{bmatrix} (t) = \begin{bmatrix} -x_2x_1 + x_3v_a(t) \\ 0 \\ 0 \end{bmatrix} + \sqrt{Q_c}v_{noise}(t) \\ y(t) &= [1 \ 0 \ 0] \begin{bmatrix} x_1 \\ x_2 \\ x_3 \end{bmatrix} (t) + \sqrt{R}\omega_{noise}(t)\end{aligned}\tag{10.4}$$

Discretize the continuous model from Equation 10.4:

$$\begin{aligned}\dot{x}(t) &= \begin{bmatrix} -x_2x_1 + x_3v_a(t) \\ 0 \\ 0 \end{bmatrix} + \sqrt{Q_c}v_{noise}(t) \\ y(t) &= [1 \ 0 \ 0] \begin{bmatrix} x_1 \\ x_2 \\ x_3 \end{bmatrix} (t) + \sqrt{R}\omega_{noise}(t)\end{aligned}\tag{10.5}$$

$$\begin{aligned}\frac{x_{k+1} - x_k}{T_s} &= \begin{bmatrix} -x_2x_1 + x_3v_a(t) \\ 0 \\ 0 \end{bmatrix} + \sqrt{Q_c}v_{noise}(t) \\ y_k &= [1 \ 0 \ 0] \begin{bmatrix} x_1 \\ x_2 \\ x_3 \end{bmatrix}_k + \sqrt{R}\omega_{noise}(t)\end{aligned}\tag{10.6}$$

Discretized nonlinear stochastic system in matrix form

$$\begin{aligned}
 x_{k+1} &= x_k + T_s \begin{bmatrix} -x_2x_1 + x_3v_{a,k} \\ 0 \\ 0 \end{bmatrix} + \sqrt{T_s Q} dv_{noise,k} \\
 y_k &= [1 \ 0 \ 0] \begin{bmatrix} x_1 \\ x_2 \\ x_3 \end{bmatrix}_k + \sqrt{R} \omega_{noise,k}
 \end{aligned} \tag{10.7}$$

10.1.2 Model the coulomb friction

From the model:

$$\dot{\omega}(t) = -a\omega(t) + bv_a(t) - c\text{sign}(\omega(t)) \tag{10.8}$$

From Equation 10.8, Let:

$$\begin{aligned}
 x_1 &= \omega \\
 x_2 &= a \\
 x_3 &= b \\
 x_4 &= c
 \end{aligned} \tag{10.9}$$

We get:

$$\begin{aligned}
 \dot{x}_1 &= \dot{\omega} = -a\omega(t) + bv_a(t) = -x_2x_1 + x_3v_a(t) - x_4\text{sign}(x_1) \\
 \dot{x}_2 &= 0 \\
 \dot{x}_3 &= 0 \\
 \dot{x}_4 &= 0
 \end{aligned} \tag{10.10}$$

In continuous nonlinear stochastic system matrix form

$$\begin{aligned}
 \dot{x}(t) &= \begin{bmatrix} \dot{x}_1 \\ \dot{x}_2 \\ \dot{x}_3 \\ \dot{x}_4 \end{bmatrix} (t) = \begin{bmatrix} -x_2x_1 + x_3v_a(t) - x_4\text{sign}(x_1) \\ 0 \\ 0 \\ 0 \end{bmatrix} + \sqrt{Q_c} v_{noise}(t) \\
 y(t) &= [1 \ 0 \ 0 \ 0] \begin{bmatrix} x_1 \\ x_2 \\ x_3 \\ x_4 \end{bmatrix} (t) + \sqrt{R} \omega_{noise}(t)
 \end{aligned} \tag{10.11}$$

Discretized nonlinear stochastic system in matrix form

$$\begin{aligned}
 x_{k+1} &= x_k + T_s \begin{bmatrix} -x_2 x_1 + x_3 v_{a,k} - x_4 \text{sign}(x_1) \\ 0 \\ 0 \\ 0 \end{bmatrix} + \sqrt{T_s Q_d} v_{noise,k} \\
 y_k &= [1 \ 0 \ 0 \ 0] \begin{bmatrix} x_1 \\ x_2 \\ x_3 \\ x_4 \end{bmatrix}_k + \sqrt{R} \omega_{noise,k}
 \end{aligned} \tag{10.12}$$

10.2 Identification using Extended Kalman Filter(EKF)

DC Motor Parameters Identification with EKF

Initialize Select any

- $\hat{x}_{0|0}$ initial state estimate
- $P_{0|0}$ positive definite error covariance matrix

Time Update

$$\begin{aligned}
 \hat{x}_{k+1|k} &= f_d(\hat{x}_{k|k}, u_k) \\
 P_{k+1|k} &= A_k P_{k|k} A_k^T + Q
 \end{aligned} \tag{10.13}$$

Measurement Update

$$\begin{aligned}
 \hat{y}_{k+1|k} &= h_d(\hat{x}_{k+1|k}, u_{k+1}) \\
 P_{xz,k+1|k} &= P_{k+1|k} C_{k+1}^T \\
 P_{zz,k+1|k} &= C_{k+1} P_{k+1|k} C_{k+1}^T + R \\
 \hat{x}_{k+1|k+1} &= \hat{x}_{k+1|k} + P_{xz,k+1|k} P_{zz,k+1|k}^{-1} (y_{k+1} - \hat{y}_{k+1|k}) \\
 P_{k+1|k+1} &= P_{k+1|k} - P_{xz,k+1|k} P_{zz,k+1|k}^{-1} P_{xz,k+1|k}^T
 \end{aligned} \tag{10.14}$$

10.2.1 Model with neglect the coulomb friction

From Equation 10.7, We have:

$$\begin{aligned}
 x_{k+1} &= x_k + T_s \begin{bmatrix} -x_2 x_1 + x_3 v_{a,k} \\ 0 \\ 0 \end{bmatrix} + \sqrt{T_s Q_d} v_{noise,k} \\
 y_k &= [1 \ 0 \ 0] \begin{bmatrix} x_1 \\ x_2 \\ x_3 \end{bmatrix}_k + \sqrt{R} \omega_{noise,k}
 \end{aligned}$$

Applying Extended Kalman Filter

Initialize state and positive definite error covariance matrix

$$\hat{x}_{0|0} = \begin{bmatrix} 2 \\ 13 \\ 25 \end{bmatrix} \text{ or some number randomly}$$

$$P_{0|0} = 2 * eye(3) = \begin{bmatrix} 2 & 0 & 0 \\ 0 & 2 & 0 \\ 0 & 0 & 2 \end{bmatrix} \text{ or some number randomly}$$

Time Update

- $T_s = 0.01$ sampling time (s) , up to user

- $Q = 0.00001 \begin{bmatrix} 10 & 0 & 0 \\ 0 & 25 & 0 \\ 0 & 0 & 25 \end{bmatrix} = 0.00001 \times diag([10 \ 25 \ 25])$

process covariance matrix, smaller is truth in process model (use for tuning)

- $R = 0.02 \begin{bmatrix} 1 & 0 & 0 \\ 0 & 1 & 0 \\ 0 & 0 & 1 \end{bmatrix} = 0.02 \times diag([1 \ 1 \ 1])$

measurement covariance matrix, smaller is truth in measurement (use for tuning)

Compute

$$\hat{x}_{k+1|k} = \hat{x}_k + T_s \begin{bmatrix} -x_2x_1 + x_3v_{a,k} \\ 0 \\ 0 \end{bmatrix} + \boxed{\sqrt{T_s Q_d} v_{noise,k}}$$

$\sqrt{T_s Q_d} v_{noise,k}$ put this bunch if we use in simulation to simulate noise to a true system, don't put if taking real value from system because the system has noise already.

Compute

$$P_{k+1|k} = A_k P_{k|k} A_k^T + Q$$

where:

$$A_k = \begin{bmatrix} -x_2 & -x_1 & v_a \\ 0 & 0 & 0 \\ 0 & 0 & 0 \end{bmatrix}$$

is the jacobian matrix calculated by derivative the state model. From Equation 10.4

$$J_f(x, y) = \begin{bmatrix} \frac{df_1}{dx_1} & \frac{df_1}{dx_2} & \frac{df_1}{dx_3} \\ \frac{df_2}{dx_1} & \frac{df_2}{dx_2} & \frac{df_2}{dx_3} \\ \frac{df_3}{dx_1} & \frac{df_3}{dx_2} & \frac{df_3}{dx_3} \end{bmatrix} = \begin{bmatrix} \frac{-x_2x_1+x_3v_a}{dx_1} & \frac{-x_2x_1+x_3v_a}{dx_2} & \frac{-x_2x_1+x_3v_a}{dx_3} \\ \frac{0}{dx_1} & \frac{0}{dx_2} & \frac{0}{dx_3} \\ \frac{0}{dx_1} & \frac{0}{dx_2} & \frac{0}{dx_3} \end{bmatrix}$$

Measurement Update

Compute $\hat{y}_{k+1|k} = h_d(\hat{x}_{k+1|k}, u_{k+1})$ measurement estimation. This equation is the estimation of a measurement would look like. In our case, we measure the ω directly (Equation 10.4) and thus we can take:

$$\hat{y}_{k+1|k} = [1 \quad 0 \quad 0] \hat{x}_{k+1|k} + D_k u_{a,k}$$

Where: $D_k = 0$

Compute

$$\begin{aligned} P_{xz,k+1|k} &= P_{k+1|k} C_{k+1}^T \\ P_{zz,k+1|k} &= C_{k+1} P_{k+1|k} C_{k+1}^T + R \end{aligned}$$

From Equation 10.4, we have $C = [1 \quad 0 \quad 0]$

Compute

$$\hat{x}_{k+1|k+1} = \hat{x}_{k+1|k} + P_{xz,k+1|k} P_{zz,k+1|k}^{-1} (y_{k+1} - \hat{y}_{k+1|k})$$

Where y_{k+1} is the measurement from sensor which has noise mixed inside. Get data directly from the sensor.

Compute

$$P_{k+1|k+1} = P_{k+1|k} - P_{xz,k+1|k} P_{zz,k+1|k}^{-1} P_{xz,k+1|k}^T$$

10.2.2 Model with coulomb friction

From Equation 10.12, We have:

$$\begin{aligned} x_{k+1} &= x_k + T_s \begin{bmatrix} -x_2 x_1 + x_3 v_{a,k} - x_4 \text{sign}(x_1) \\ 0 \\ 0 \\ 0 \end{bmatrix} + \sqrt{T_s Q_d} v_{noise,k} \\ y_k &= [1 \quad 0 \quad 0 \quad 0] \begin{bmatrix} x_1 \\ x_2 \\ x_3 \\ x_4 \end{bmatrix}_k + \sqrt{R} \omega_{noise,k} \end{aligned}$$

Applying Extended Kalman Filter

Initialize state and positive definite error covariance matrix

$$\hat{x}_{0|0} = \begin{bmatrix} 2 \\ 13 \\ 25 \\ 1 \end{bmatrix} \text{ or some number randomly}$$

$$P_{0|0} = 2 * \text{eye}(4) = \begin{bmatrix} 2 & 0 & 0 & 0 \\ 0 & 2 & 0 & 0 \\ 0 & 0 & 2 & 0 \\ 0 & 0 & 0 & 2 \end{bmatrix} \text{ or some number randomly}$$

Time Update

- $T_s = 0.01$ sampling time (s) , up to user

- $Q = 0.00001 \begin{bmatrix} 10 & 0 & 0 & 0 \\ 0 & 25 & 0 & 0 \\ 0 & 0 & 25 & 0 \\ 0 & 0 & 0 & 1 \end{bmatrix} = 0.00001 \times \text{diag}([10 \quad 25 \quad 25 \quad 1])$

process covariance matrix, smaller is truth in process model (use for tuning)

- $R = 0.02 \begin{bmatrix} 1 & 0 & 0 & 0 \\ 0 & 1 & 0 & 0 \\ 0 & 0 & 1 & 0 \\ 0 & 0 & 0 & 1 \end{bmatrix} = 0.02 \times \text{diag}([1 \quad 1 \quad 1 \quad 1])$

measurement covariance matrix, smaller is truth in measurement (use for tuning)

Compute

$$\hat{x}_{k+1|k} = \hat{x}_k + T_s \begin{bmatrix} -x_2x_1 + x_3v_{a,k} - x_4\text{sign}(x_1) \\ 0 \\ 0 \\ 0 \end{bmatrix} + \boxed{\sqrt{T_s Q_d} v_{noise,k}}$$

Compute

$$P_{k+1|k} = A_k P_{k|k} A_k^T + Q$$

where:

$$A_k = \begin{bmatrix} -x_2 & -x_1 & v_a & -\text{sign}(x_1) \\ 0 & 0 & 0 & 0 \\ 0 & 0 & 0 & 0 \\ 0 & 0 & 0 & 0 \end{bmatrix}$$

is the jacobian matrix calculated by derivative the state model from Equation 10.11.

Measurement Update**Compute**

$$\hat{y}_{k+1|k} = [1 \quad 0 \quad 0 \quad 0] \hat{x}_{k+1|k} + D_k u_{a,k}$$

Where: $D_k = 0$

Compute

$$P_{xz,k+1|k} = P_{k+1|k} C_{k+1}^T$$

$$P_{zz,k+1|k} = C_{k+1} P_{k+1|k} C_{k+1}^T + R$$

From Equation 10.11, we have $C = [1 \quad 0 \quad 0 \quad 0]$

Compute

$$\hat{x}_{k+1|k+1} = \hat{x}_{k+1|k} + P_{xz,k+1|k} P_{zz,k+1|k}^{-1} (y_{k+1} - \hat{y}_{k+1|k})$$

Where y_{k+1} is the measurement from sensor which has noise mixed inside. Get data directly from the sensor.

Compute

$$P_{k+1|k+1} = P_{k+1|k} - P_{xz,k+1|k} P_{zz,k+1|k}^{-1} P_{xz,k+1|k}^T$$

```

1  function x_est = EKF(uk,y_true)
2  Ts=0.01;
3  persistent x_est_p P Qd_est R_est Qc_est;
4  if isempty(x_est_p)
5  x_est_p = [2;13;25;1];
6
7  P = 2*[1 0 0 0;
8  0 1 0 0;
9  0 0 1 0;
10 0 0 0 1]; %2*eye(4);
11
12 Qc_est = 1e-5*[10 0 0 0;
13 0 25 0 0;
14 0 0 25 0;
15 0 0 0 1]; %1e-5*diag([10,25,25,1]);
16
17 Qd_est=Qc_est*Ts;
18
19 R_est=0.02;
20 end
21
22 c=[1 0 0 0]; D=0; Ck=c; Dk=D;
23
24 %Compute Kalman Gain and update predicted value
25 Wk=P*Ck'/(Ck*P*Ck'+R_est);
26
27 y_est=Ck*x_est_p+Dk*uk;
28
29 x=x_est_p+Wk.*(y_true-y_est);
30
31 %Compute prediction at next time step
32 x_est=x+Ts*[-x(2)*x(1)+uk*x(3)-x(4)*sign(x(1));
33 0 ;
34 0 ;
35 0 ];
36
37 %Update error covariance matrices
38 P=P-Wk*Ck*P;
39
40 %Define Ak
41 Ak=eye(4)+Ts*[-x(2) -x(1) uk -sign(x(1));
42 0 0 0 0 ;
43 0 0 0 0 ;
44 0 0 0 0 ]; % jacobian
45
46 P=Ak*P*Ak'+Qd_est;
47
48 x_est_p=x_est;

```

Chapter 11

DC Motor Control

In application of DC Motor, we want to be able to control its position and angular velocity.

11.1 Velocity Control using PI Control

In this section we design a controller for dcmotor based on linearized dcmotor model using 2nd Order Differential Equation Design Workflow. From DC motor Model, we have:

$$\dot{\omega}(t) = -a\omega(t) + bv_a(t) \quad (11.1)$$

We have to design a velocity controller, thus the feedback of the system is angular velocity of the dc motor.

We have our PI control:

$$v_a(t) = K_p(\omega_d(t) - \omega(t)) + K_i \int_0^t (\omega_d(t) - \omega(t)) dt \quad (11.2)$$

From Equation 11.1, we get:

$$v_a(t) = \frac{1}{b}\dot{\omega}_d(t) + \frac{a}{b}\omega_d(t) \quad (11.3)$$

From Equation 11.2 and Equation 11.3, we have our controller design:

$$v_a(t) = \frac{1}{b}\dot{\omega}_d(t) + \frac{a}{b}\omega_d(t) + K_p(\omega_d(t) - \omega(t)) + K_i \int_0^t (\omega_d(t) - \omega(t)) dt \quad (11.4)$$

Substitute Equation 11.4 back to model in Equation 11.1, we get:

$$\dot{\omega}(t) = -a\omega(t) + b \left(\frac{1}{b}\dot{\omega}_d(t) + \frac{a}{b}\omega_d(t) + K_p(\omega_d(t) - \omega(t)) + K_i \int_0^t (\omega_d(t) - \omega(t)) dt \right) \quad (11.5)$$

$$0 = -\dot{\omega}(t) - a\omega(t) + \dot{\omega}_d(t) + a\omega_d(t) + bK_p(\omega_d(t) - \omega(t)) + bK_i \int_0^t (\omega_d(t) - \omega(t)) dt$$

$$0 = (\dot{\omega}_d(t) - \dot{\omega}(t)) + a(\omega_d(t) - \omega(t)) + bK_p(\omega_d(t) - \omega(t)) + bK_i \int_0^t (\omega_d(t) - \omega(t)) dt$$

$$0 = (\dot{\omega}_d(t) - \dot{\omega}(t)) + (a + bK_p)(\omega_d(t) - \omega(t)) + bK_i \int_0^t (\omega_d(t) - \omega(t)) dt$$

$$0 = \dot{e}_\omega + (a + bK_p)e_\omega + bK_i \int_0^t e_\omega dt$$

$$0 = \ddot{e}_\omega + (a + bK_p)\dot{e}_\omega + bK_i e_\omega \leftarrow \text{take derivative to cancel integral.}$$

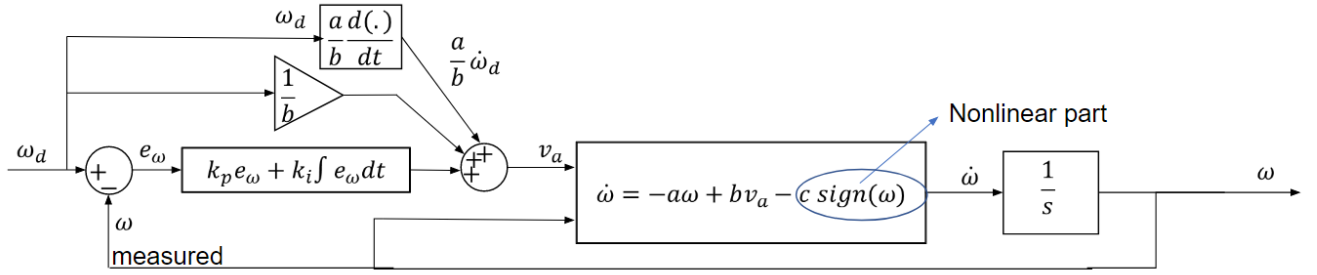

Figure 11.1: Velocity Control PI Controller

Thus, we get:

$$\ddot{e}_\omega + (a + bK_p)\dot{e}_\omega + bK_i e_\omega = 0 \quad (11.6)$$

From 2nd Order differential equation standard form, we have:

$$\ddot{X} + 2\zeta\omega_n\dot{X} + \omega_n^2 X = 0 \quad (11.7)$$

From Equation 11.6 and Equation 11.7, we get:

$$\begin{aligned} a + bK_p &= 2\zeta\omega_n \\ bK_i &= \omega_n^2 \\ K_p &= \frac{2\zeta\omega_n - a}{b} \\ K_i &= \frac{\omega_n^2}{b} \end{aligned}$$

From equation above, we want $K_p > 0$. Thus, $2\zeta\omega_n > a$, then $\zeta\omega_n > \frac{a}{2}$ to ensure stability.

Velocity Control using PI Linear

Control input

$$v_a(t) = \frac{1}{b}\dot{\omega}_d(t) + \frac{a}{b}\omega_d(t) + K_p(\omega_d(t) - \omega(t)) + K_i \int_0^t (\omega_d(t) - \omega(t)) dt$$

Control Tuning Constant

$$\begin{aligned} K_p &= \frac{2\zeta\omega_n - a}{b} \\ K_i &= \frac{\omega_n^2}{b} \end{aligned}$$

11.2 Velocity Control using PID Control

In this section we design a controller for dcmotor based on linearized dcmotor model using 2nd Order Differential Equation Design Workflow. From DC motor Model, We have our PID control:

$$v_a(t) = K_p(\omega_d(t) - \omega(t)) + K_i \int_0^t (\omega_d(t) - \omega(t)) dt + K_d \frac{d}{dt}(\omega_d(t) - \omega(t)) \quad (11.8)$$

From Equation 11.3 and Equation 11.8, we have our controller design:

$$v_a(t) = \frac{1}{b}\dot{\omega}_d(t) + \frac{a}{b}\omega_d(t) + K_p(\omega_d(t) - \omega(t)) + K_i \int_0^t (\omega_d(t) - \omega(t)) dt + K_d \frac{d}{dt}(\omega_d(t) - \omega(t)) \quad (11.9)$$

Substitute Equation 11.9 back to model in Equation 11.1, we get:

$$\dot{\omega} = -a\omega + b \left(\frac{1}{b}\dot{\omega}_d + \frac{a}{b}\omega_d + K_p(\omega_d - \omega) + K_i \int_0^t (\omega_d - \omega) dt + K_d \frac{d}{dt}(\omega_d - \omega) \right) \quad (11.10)$$

$$0 = -\dot{\omega} - a\omega + b \left(\frac{1}{b}\dot{\omega}_d + \frac{a}{b}\omega_d + K_p(\omega_d - \omega) + K_i \int_0^t (\omega_d - \omega) dt + K_d \frac{d}{dt}(\omega_d - \omega) \right)$$

$$0 = -\dot{\omega} - a\omega + \dot{\omega}_d + a\omega_d + bK_p(\omega_d - \omega) + bK_i \int_0^t (\omega_d - \omega) dt + bK_d \frac{d}{dt}(\omega_d - \omega)$$

$$0 = (\dot{\omega}_d - \dot{\omega}) + (a + bK_p)(\omega_d - \omega) + bK_i \int_0^t (\omega_d - \omega) dt + bK_d \frac{d}{dt}(\omega_d - \omega)$$

$$0 = (1 + bK_d)(\dot{\omega}_d - \dot{\omega}) + (a + bK_p)(\omega_d - \omega) + bK_i \int_0^t (\omega_d - \omega) dt$$

$$0 = (1 + bK_d)\dot{e}_\omega + (a + bK_p)e_\omega + bK_i \int_0^t e_\omega dt$$

$$0 = (1 + bK_d)\ddot{e}_\omega + (a + bK_p)\dot{e}_\omega + bK_i e_\omega$$

Thus, we get:

$$\begin{aligned} (1 + bK_d)\ddot{e}_\omega + (a + bK_p)\dot{e}_\omega + bK_i e_\omega &= 0 \\ \ddot{e}_\omega + \frac{(a + bK_p)}{(1 + bK_d)}\dot{e}_\omega + \frac{bK_i}{(1 + bK_d)}e_\omega &= 0 \end{aligned} \quad (11.11)$$

From 2nd Order differential equation standard form Equation 11.7, we have:

$$\begin{aligned} \frac{(a + bK_p)}{(1 + bK_d)} &= 2\zeta\omega_n \\ \frac{bK_i}{(1 + bK_d)} &= \omega_n^2 \end{aligned}$$

Velocity Control using PID Linear

Control input

$$v_a(t) = K_p(\omega_d(t) - \omega(t)) + K_i \int_0^t (\omega_d(t) - \omega(t)) dt + K_d \frac{d}{dt}(\omega_d(t) - \omega(t))$$

Control Tuning Constant We have more freedom to choose Kp Ki Kd, that satisfied :

$$\begin{aligned} \frac{(a + bK_p)}{(1 + bK_d)} &= 2\zeta\omega_n \\ \frac{bK_i}{(1 + bK_d)} &= \omega_n^2 \end{aligned}$$

11.3 Position Control using PID Control

In this section we design a controller for dcmotor based on linearized dcmotor model using 2nd/3rd Order Differential Equation Design Workflow. From DC motor Model, We have our PID control:

$$v_a(t) = K_p(\theta_d(t) - \theta(t)) + K_i \int_0^t (\theta_d(t) - \theta(t)) dt + K_d \frac{d}{dt}(\theta_d(t) - \theta(t)) \quad (11.12)$$

From Equation 11.1, it can be written in form of position as:

$$\ddot{\theta}(t) = -a\dot{\theta}(t) + bv_a(t) \quad (11.13)$$

Thus, we get:

$$v_a(t) = \frac{1}{b}\ddot{\theta}_d(t) + \frac{a}{b}\dot{\theta}_d(t) \quad (11.14)$$

From Equation 11.13 and Equation 11.14, we have our controller design:

$$v_a(t) = \frac{1}{b}\ddot{\theta}_d(t) + \frac{a}{b}\dot{\theta}_d(t) + K_p(\theta_d(t) - \theta(t)) + K_i \int_0^t (\theta_d(t) - \theta(t)) dt + K_d \frac{d}{dt}(\theta_d(t) - \theta(t)) \quad (11.15)$$

Substitute Equation 11.15 to Equation 11.13, we get:

$$\ddot{\theta} = -a\dot{\theta} + b \left(\frac{1}{b}\ddot{\theta}_d + \frac{a}{b}\dot{\theta}_d + K_p(\theta_d - \theta) + K_i \int_0^t (\theta_d - \theta) dt + K_d \frac{d}{dt}(\theta_d - \theta) \right) \quad (11.16)$$

$$\ddot{\theta} = -a\dot{\theta} + \ddot{\theta}_d + a\dot{\theta}_d + bK_p(\theta_d - \theta) + bK_i \int_0^t (\theta_d - \theta) dt + bK_d \frac{d}{dt}(\theta_d - \theta)$$

$$0 = -\ddot{\theta} - a\dot{\theta} + \ddot{\theta}_d + a\dot{\theta}_d + bK_p(\theta_d - \theta) + bK_i \int_0^t (\theta_d - \theta) dt + bK_d \frac{d}{dt}(\theta_d - \theta)$$

$$0 = (\ddot{\theta}_d - \ddot{\theta}) + a(\dot{\theta}_d - \dot{\theta}) + bK_p(\theta_d - \theta) + bK_i \int_0^t (\theta_d - \theta) dt + bK_d(\dot{\theta}_d - \dot{\theta})$$

$$0 = (\ddot{\theta}_d - \ddot{\theta}) + (a + bK_d)(\dot{\theta}_d - \dot{\theta}) + bK_p(\theta_d - \theta) + bK_i \int_0^t (\theta_d - \theta) dt$$

$$0 = \ddot{e}_\theta + (a + bK_d)\dot{e}_\theta + bK_p e_\theta + bK_i \int_0^t e_\theta dt$$

$$0 = \ddot{e}_\theta + (a + bK_d)\dot{e}_\theta + bK_p e_\theta + bK_i e_\theta$$

Thus, we get:

$$\ddot{e}_\theta + (a + bK_d)\dot{e}_\theta + bK_p e_\theta + bK_i e_\theta = 0 \quad (11.17)$$

is the 3rd order differential equation with the characteristic form of:

$$\lambda^3 + (a + bK_d)\lambda^2 + bK_p\lambda + bK_i = 0 \quad (11.18)$$

From Equation 11.18, we know that in 3rd order differential equation characteristic polynomial, there exist 3 roots and at least 1 root is real root (denoted by λ_1). Thus, we can write:

$$\begin{aligned} (\lambda + \lambda_1)(\lambda^2 + 2\zeta\omega_n\lambda + \omega_n^2) &= 0 \\ \lambda^3 + 2\zeta\omega_n\lambda^2 + \omega_n^2\lambda + \lambda_1\lambda^2 + 2\zeta\omega_n\lambda\lambda_1 + \omega_n^2\lambda_1 &= 0 \\ \lambda^3 + (2\zeta\omega_n + \lambda_1)\lambda^2 + (2\zeta\omega_n\lambda_1 + \omega_n^2)\lambda + \omega_n^2\lambda_1 &= 0 \end{aligned} \quad (11.19)$$

From Equation 11.18 and Equation 11.19, we have:

$$\begin{aligned}
 a + bK_d &= 2\zeta\omega_n + \lambda_1 \\
 bK_p &= 2\zeta\omega_n\lambda_1 + \omega_n^2 \\
 bK_i &= \omega_n^2\lambda_1 \\
 K_d &= \frac{2\zeta\omega_n + \lambda_1 - a}{b} \\
 K_p &= \frac{2\zeta\omega_n\lambda_1 + \omega_n^2}{b} \\
 K_i &= \frac{\omega_n^2\lambda_1}{b}
 \end{aligned}$$

Velocity Control using PID Linear

Control input

$$v_a(t) = K_p(\theta_d(t) - \theta(t)) + K_i \int_0^t (\theta_d(t) - \theta(t)) dt + K_d \frac{d}{dt}(\theta_d(t) - \theta(t))$$

Control Tuning Constant

$$\begin{aligned}
 K_d &= \frac{2\zeta\omega_n + \lambda_1 - a}{b} \\
 K_p &= \frac{2\zeta\omega_n\lambda_1 + \omega_n^2}{b} \\
 K_i &= \frac{\omega_n^2\lambda_1}{b}
 \end{aligned}$$

Chapter 12

DC Motor Cascade Control

12.1 Outer P Velocity and Inner PI Torque Control Design

In this section, we design a cascade controller for demotor with Outer Propositional Velocity and Inner Propositional Integral Torque Control Design.

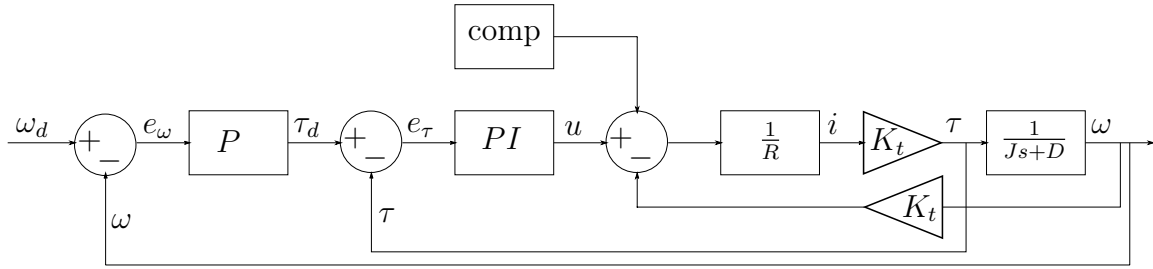

Assumption $L = 0, K_b = K_t, T_c \neq 0$ From the Architecture, We have:

- $u = K_{pi}e_\tau + K_{ii} \int e_\tau dt + comp$
- $e_\omega = \omega_d - \omega \Rightarrow \dot{e}_\omega = \dot{\omega}_d - \dot{\omega}$
- $e_\tau = \tau_d - \tau \Rightarrow \dot{e}_\tau = \dot{\tau}_d - \dot{\tau}$
- $\tau_d = K_{po}e_\omega \Rightarrow \dot{\tau}_d = K_{po}\dot{e}_\omega$

From the Model of DC Model, We have:

$$u = K_t \omega + Ri$$

$$\Rightarrow i = \frac{u - K_t \omega}{R}$$

We have:

$$\tau = K_t i = T_c + D\omega + J\dot{\omega}$$

By Substitute i in, We get:

$$K_t \frac{u - K_t \omega}{R} = T_c + D\omega + J\dot{\omega}$$

$$RT_c + RD\omega + RJ\dot{\omega} = K_t(u - K_t \omega)$$

$$\frac{RJ}{K_t} \dot{\omega} + \frac{RD + K_t^2}{K_t} \omega + \frac{RT_c}{K_t} = u$$

Substitute u in, We get:

$$\frac{RJ}{K_t}\dot{\omega} + \frac{RD + K_t^2}{K_t}\omega + \frac{RT_c}{K_t} = K_{pi}e_\tau + K_{ii} \int e_\tau dt + comp$$

Take Derivative to eliminate integral:

$$\begin{aligned} \frac{RJ}{K_t}\ddot{\omega} + \frac{RD + K_t^2}{K_t}\dot{\omega} &= K_{pi}\dot{e}_\tau + K_{ii}e_\tau + comp \\ \frac{RJ}{K_t}\ddot{\omega} + \frac{RD + K_t^2}{K_t}\dot{\omega} &= K_{pi}(\dot{\tau}_d - \dot{\tau}) + K_{ii}(\tau_d - \tau) + comp \end{aligned}$$

From the model, We have:

$$\tau = T_c + D\omega + J\dot{\omega} \Rightarrow \dot{\tau} = D\dot{\omega} + J\ddot{\omega}$$

We get:

$$\begin{aligned} \frac{RJ}{K_t}\ddot{\omega} + \frac{RD + K_t^2}{K_t}\dot{\omega} &= K_{pi}(K_{po}\dot{e}_\omega - (D\dot{\omega} + J\ddot{\omega})) + K_{ii}(K_{po}e_\omega - (T_c + D\omega + J\dot{\omega})) + comp \\ \frac{RJ}{K_t}\ddot{\omega} + \frac{RD + K_t^2}{K_t}\dot{\omega} &= K_{pi}(K_{po}\dot{e}_\omega - D\dot{\omega} - J\ddot{\omega}) + K_{ii}(K_{po}e_\omega - T_c - D\omega - J\dot{\omega}) + comp \\ \frac{RJ}{K_t}\ddot{\omega} + \frac{RD + K_t^2}{K_t}\dot{\omega} &= K_{pi}K_{po}\dot{e}_\omega - K_{pi}D\dot{\omega} - K_{pi}J\ddot{\omega} + K_{ii}K_{po}e_\omega - K_{ii}T_c - K_{ii}D\omega - K_{ii}J\dot{\omega} + comp \\ \frac{RJ}{K_t}\ddot{\omega} + \frac{RD + K_t^2}{K_t}\dot{\omega} + K_{pi}D\dot{\omega} + K_{pi}J\ddot{\omega} + K_{ii}D\omega + K_{ii}J\dot{\omega} &= K_{pi}K_{po}\dot{e}_\omega + K_{ii}K_{po}e_\omega - K_{ii}T_c + comp \\ \left(\frac{RJ}{K_t} + K_{pi}J\right)\ddot{\omega} + \left(\frac{RD + K_t^2}{K_t} + K_{pi}D + K_{ii}J\right)\dot{\omega} + K_{ii}D\omega &= K_{pi}K_{po}\dot{e}_\omega + K_{ii}K_{po}e_\omega - K_{ii}T_c + comp \end{aligned}$$

Multiply both side by -1 to reverse the sign:

$$-\left(\frac{RJ}{K_t} + K_{pi}J\right)\ddot{\omega} - \left(\frac{RD + K_t^2}{K_t} + K_{pi}D + K_{ii}J\right)\dot{\omega} - K_{ii}D\omega = -K_{pi}K_{po}\dot{e}_\omega - K_{ii}K_{po}e_\omega + K_{ii}T_c - comp$$

Adding both of the equation for compensation with :

$$\begin{aligned} &+ \left(\frac{RJ}{K_t} + K_{pi}J\right)\ddot{\omega}_d \\ &+ \left(\frac{RD + K_t^2}{K_t} + K_{pi}D + K_{ii}J\right)\dot{\omega}_d \\ &+ K_{ii}D\omega_d \end{aligned}$$

We get:

On LHS:

$$\left(\frac{RJ}{K_t} + K_{pi}J\right)(\ddot{\omega}_d - \ddot{\omega}) + \left(\frac{RD + K_t^2}{K_t} + K_{pi}D + K_{ii}J\right)(\dot{\omega}_d - \dot{\omega}) + K_{ii}D(\omega_d - \omega) =$$

On RHS:

$$= -K_{pi}K_{po}\dot{e}_\omega - K_{ii}K_{po}e_\omega + K_{ii}T_c - comp + \left(\frac{RJ}{K_t} + K_{pi}J\right)\ddot{\omega}_d + \left(\frac{RD + K_t^2}{K_t} + K_{pi}D + K_{ii}J\right)\dot{\omega}_d + K_{ii}D\omega_d$$

Then:

On LHS:

$$\left(\frac{RJ}{K_t} + K_{pi}J\right)\ddot{e}_\omega + \left(\frac{RD + K_t^2}{K_t} + K_{pi}D + K_{ii}J\right)\dot{e}_\omega + K_{ii}De_\omega + K_{pi}K_{po}\dot{e}_\omega + K_{ii}K_{po}e_\omega =$$

On RHS:

$$= K_{ii}T_c - comp + \left(\frac{RJ}{K_t} + K_{pi}J\right)\ddot{\omega}_d + \left(\frac{RD + K_t^2}{K_t} + K_{pi}D + K_{ii}J\right)\dot{\omega}_d + K_{ii}D\omega_d$$

On LHS:

$$\left(\frac{RJ}{K_t} + K_{pi}J\right)\ddot{e}_\omega + \left(\frac{RD + K_t^2}{K_t} + K_{pi}D + K_{ii}J + K_{pi}K_{po}\right)\dot{e}_\omega + (K_{ii}D + K_{ii}K_{po})e_\omega =$$

On RHS:

$$= K_{ii}T_c - comp + \left(\frac{RJ}{K_t} + K_{pi}J\right)\ddot{\omega}_d + \left(\frac{RD + K_t^2}{K_t} + K_{pi}D + K_{ii}J\right)\dot{\omega}_d + K_{ii}D\omega_d$$

On the LHS, Using the 2nd Order Differential Standard Form : $\ddot{X} + 2\zeta\omega_n\dot{X} + \omega_n^2X = 0$,
We get:

$$2\zeta\omega_n = \frac{\left(\frac{RD+K_t^2}{K_t} + K_{pi}D + K_{ii}J + K_{pi}K_{po}\right)}{\left(\frac{RJ}{K_t} + K_{pi}J\right)}$$

$$\omega_n^2 = \frac{(K_{ii}D + K_{ii}K_{po})}{\left(\frac{RJ}{K_t} + K_{pi}J\right)}$$

We solve above equation for K_{pi} and K_{ii} in terms of K_{po}, ζ, ω_n , We get:

$$K_{pi} = -\frac{D^2R + J^2R\omega_n^2 + k_{po}(K_t^2 - 2JR\omega_n\zeta) + D(K_t^2 + R(k_{po} - 2J\omega_n\zeta))}{K_t(D^2 + k_{po}^2 + J^2\omega_n^2 - 2Jk_{po}\omega_n\zeta + 2D(k_{po} - J\omega_n\zeta))}$$

$$K_{ii} = \frac{J(-K_t^2 + k_{po}R)\omega_n^2}{K_t(D^2 + k_{po}^2 + J^2\omega_n^2 - 2Jk_{po}\omega_n\zeta + 2D(k_{po} - J\omega_n\zeta))}$$

On the RHS, We have our compensation:

$$comp = K_{ii}T_c + \left(\frac{RJ}{K_t} + K_{pi}J\right)\ddot{\omega}_d + \left(\frac{RD + K_t^2}{K_t} + K_{pi}D + K_{ii}J\right)\dot{\omega}_d + K_{ii}D\omega_d$$

$$comp = \int \left[K_{ii}T_c + \left(\frac{RJ}{K_t} + K_{pi}J\right)\ddot{\omega}_d + \left(\frac{RD + K_t^2}{K_t} + K_{pi}D + K_{ii}J\right)\dot{\omega}_d + K_{ii}D\omega_d \right] dt$$

Chapter 13

Kalman Filter

Kalman Filter was found by Dr. Rudolf Emil Kálmán. This algorithm is a powerful filtering algorithm that has been used in many applications most notably in signal processing, control, optimization, sensor fusion, system identification -etc , and it is able to be implemented online.

13.1 Kalman Filter (Linear System)

Consider a linear discrete time system as following:

$$\begin{aligned}x_{k+1} &= Ax_k + Bu_k + v_k \\y_{k+1} &= Cx_{k+1} + Du_{k+1} + w_{k+1}\end{aligned}\tag{13.1}$$

Where:

- $x_k \in \mathbb{R}^{n_x}$ state system
- $u_k \in \mathbb{R}^{n_u}$ input system
- $y_k \in \mathbb{R}^{n_z}$ measurement system
- $A \in \mathbb{R}^{n_x \times n_x}$ system matrix
- $C \in \mathbb{R}^{n_z \times n_x}$ observation matrix
- $B \in \mathbb{R}^{n_x \times n_u}$ some matrix
- $D \in \mathbb{R}^{n_z \times n_u}$ some matrix
- $v_k \in \mathbb{R}^{n_x}$ independent process noises
- $w_k \in \mathbb{R}^{n_z}$ independent measurement noises
- $Q \in \mathbb{R}^{n_x \times n_x}$ Gaussian covariance matrix of v
- $R \in \mathbb{R}^{n_z \times n_z}$ Gaussian covariance matrix of w

Apply Kalman Filter on the system

Initialize Select any

- $\hat{x}_{0|0}$ initial state estimate
- $P_{0|0}$ positive definite error covariance matrix

Time Update

$$\begin{aligned}\hat{x}_{k+1|k} &= A\hat{x}_{k|k} + Bu_k \\ P_{k+1|k} &= AP_{k|k}A^T + Q\end{aligned}\tag{13.2}$$

Measurement Update

$$\begin{aligned}\hat{y}_{k+1|k} &= C\hat{x}_{k+1|k} + Du_{k+1} \\ P_{xy,k+1|k} &= P_{k+1|k}C^T \\ P_{yy,k+1|k} &= CP_{k+1|k}C^T + R \\ \hat{x}_{k+1|k+1} &= \hat{x}_{k+1|k} + P_{xy,k+1|k}P_{yy,k+1|k}^{-1}(y_k - \hat{y}_{k+1|k}) \\ P_{k+1|k+1} &= P_{k+1|k} - P_{xy,k+1|k}P_{yy,k+1|k}^{-1}P_{xy,k+1|k}^T\end{aligned}\tag{13.3}$$

In terms of Kalman Gain,

$$\begin{aligned}K_{k+1} &= P_{xy,k+1|k}P_{yy,k+1|k}^{-1} \\ \hat{x}_{k+1|k+1} &= \hat{x}_{k+1|k} + K_{k+1}(y_{k+1} - C\hat{x}_{k+1|k} - Du_{k+1}) \\ P_{k+1|k+1} &= P_{k+1|k} - K_{k+1}P_{yy,k+1|k}K_{k+1}^T\end{aligned}\tag{13.4}$$

13.2 Extended Kalman Filter (Nonlinear System)

Consider a nonlinear discrete time system as following:

$$\begin{aligned}x_{k+1} &= f_d(x_k + u_k) + v_k \\ y_{k+1} &= h_d(x_{k+1}, u_{k+1}) + w_{k+1}\end{aligned}\tag{13.5}$$

Where:

- $x_k \in \mathbb{R}^{n_x}$ state system at discrete time
- $u_k \in \mathbb{R}^{n_u}$ input system
- $y_k \in \mathbb{R}^{n_z}$ measurement
- f_d some known function
- h_d some known function
- $v_k \in \mathbb{R}^{n_x}$ independent process noises
- $w_k \in \mathbb{R}^{n_z}$ independent measurement noises

Apply Extended Kalman Filter on the system

Initialize Select any

- $\hat{x}_{0|0}$ initial state estimate
- $P_{0|0}$ positive definite error covariance matrix

Time Update

$$\begin{aligned}\hat{x}_{k+1|k} &= f_d(\hat{x}_{k|k}, u_k) \\ P_{k+1|k} &= A_k P_{k|k} A_k^T + Q\end{aligned}\tag{13.6}$$

Measurement Update

$$\begin{aligned}\hat{y}_{k+1|k} &= h_d(\hat{x}_{k+1|k}, u_{k+1}) \\ P_{xy,k+1|k} &= P_{k+1|k} C_{k+1}^T \\ P_{yy,k+1|k} &= C_{k+1} P_{k+1|k} C_{k+1}^T + R \\ \hat{x}_{k+1|k+1} &= \hat{x}_{k+1|k} + P_{xy,k+1|k} P_{yy,k+1|k}^{-1} (y_{k+1} - \hat{y}_{k+1|k}) \\ P_{k+1|k+1} &= P_{k+1|k} - P_{xy,k+1|k} P_{yy,k+1|k}^{-1} P_{xy,k+1|k}^T\end{aligned}\tag{13.7}$$

In terms of Kalman Gain,

$$\begin{aligned}K_{k+1} &= P_{xy,k+1|k} P_{yy,k+1|k}^{-1} \\ \hat{x}_{k+1|k+1} &= \hat{x}_{k+1|k} + K_{k+1} [y_{k+1} - h_d(\hat{x}_{k+1|k}, u_{k+1})] \\ P_{k+1|k+1} &= P_{k+1|k} - K_{k+1} P_{yy,k+1|k} K_{k+1}^T\end{aligned}\tag{13.8}$$

Where from linearization of nonlinear function f_d and h_d using a Taylor series expansion, We get Jacobian matrix:

$$\begin{aligned}A_k &= \left. \frac{\partial f_d}{\partial x} \right|_{x=\hat{x}_{k|k}} \\ C_{k+1} &= \left. \frac{\partial h_d}{\partial x} \right|_{x=\hat{x}_{k+1|k}}\end{aligned}$$

13.3 Unscented Kalman Filter (Nonlinear System)

Consider a nonlinear discrete time system as following:

$$\begin{aligned}x_{k+1} &= f_d(x_k + u_k) + v_k \\ y_{k+1} &= h_d(x_{k+1}, u_{k+1}) + w_{k+1}\end{aligned}\tag{13.9}$$

Apply Unscented Kalman Filter on the system

Initialize

- $\hat{x}_{0|0}$ initial state estimate
- $P_{0|0}$ positive definite error covariance matrix

Time Update

$$\begin{aligned}
X_{k|k} &= [\hat{x}_{k|k} \quad \dots \quad \hat{x}_{k|k}] + \sqrt{n_x + \lambda} [0 \quad \sqrt{P_{k|k}} \quad -\sqrt{P_{k|k}}] \\
X_{k+1|k} &= f_d(X_{k|k}, u_k) \\
\hat{x}_{k+1|k} &= X_{k+1|k} w_m \\
P_{k+1|k} &= X_{k+1|k} W X_{k+1|k}^T + Q
\end{aligned} \tag{13.10}$$

Measurement Update

$$\begin{aligned}
X_{k+1|k}^{(r)} &= [\hat{x}_{k+1|k} \quad \dots \quad \hat{x}_{k+1|k}] + \sqrt{n_x + \lambda} [0 \quad \sqrt{P_{k+1|k}} \quad -\sqrt{P_{k+1|k}}] \\
Y_{k+1|k} &= h_d(X_{k+1|k}^{(r)}, u_{k+1}) \\
\hat{y}_{k+1|k} &= Y_{k+1|k} w_m \\
P_{xy,k+1|k} &= X_{k+1|k}^{(r)} W Y_{k+1|k}^T \\
P_{yy,k+1|k} &= Y_{k+1|k} W Y_{k+1|k}^T + R \\
K_{k+1} &= P_{xy,k+1|k} P_{yy,k+1|k}^{-1} \\
\hat{x}_{k+1|k+1} &= \hat{x}_{k+1|k} + K_{k+1} (y_{k+1} - \hat{y}_{k+1|k}) \\
P_{k+1|k+1} &= P_{k+1|k} - K_{k+1} P_{yy,k+1|k} K_{k+1}^T
\end{aligned} \tag{13.11}$$

Chapter 14

Sensor Fusion

For filtering out noise of sensor and predicting the future change of state when there is an absence of sensor data, we use method of sensor fusion. There numerous way of doing a sensor fusion. Below are some of the application for sensor fusion.

14.1 Differential Drive Robot Sensor Fusion for Linear and Angular Velocity

In differential drive robot, we have a position model:

$$\begin{bmatrix} \dot{x} \\ \dot{y} \\ \dot{\theta} \end{bmatrix}_{global} = \begin{bmatrix} V \cos \theta \\ V \sin \theta \\ \omega \end{bmatrix} \quad (14.1)$$

Where:

- $\begin{bmatrix} \dot{x} \\ \dot{y} \\ \dot{\theta} \end{bmatrix}_{global}$ is rate of change of position of the robot inside a global frame reference
- θ is the heading angle of the robot inside a global frame
- V is the linear velocity of the robot inside a local robot frame
- ω is the angular velocity of the robot inside a local robot frame

Our purpose is to estimate the V and ω

Those two variable can be calculated from two sources: Wheel Encoder and IMU.

14.1.1 From Wheel Encoder

From differential drive robot kinematic model, We have:

$$V(t) = \dot{\phi}_r \frac{r}{2} + \dot{\phi}_l \frac{r}{2} \quad (14.2)$$

$$\omega(t) = \dot{\phi}_r \frac{r}{L} - \dot{\phi}_l \frac{r}{L} \quad (14.3)$$

Where:

- $\dot{\phi}_r$ is the rotation velocity of the right wheel
- $\dot{\phi}_l$ is the rotation velocity of the left wheel
- r is the wheel radius
- L is the robot based length

Wheel rotation velocity is calculated from the wheel encoder by:

$$\dot{\phi} = \frac{\phi_{k+1} - \phi_k}{T_s} \quad (14.4)$$

$$\phi = \frac{2 \times \pi \times \text{encoder ticks}}{\text{GearBox} \times \text{Pulse per Revolution}} \quad (14.5)$$

14.1.2 From IMU Sensor

We have:

$$\dot{V} = a_{imu-x} + b \quad (14.6)$$

$$\omega = \omega_{imu} + b \quad (14.7)$$

Where:

- a_{imu-x} is the imu accelerometer in x-axis local frame
- ω_{imu-z} is the imu gyroscope in z-axis local frame
- b is the biased of imu measurement

14.1.3 Estimate V

From model:

$$\begin{aligned} \dot{V} &= a_{imu-x} + b \\ \dot{b} &= 0 \end{aligned} \quad (14.8)$$

Let:

$$\begin{aligned} x_1 = V &\rightarrow \dot{x}_1 = a_{imu-x} + b \\ x_2 = b &\rightarrow \dot{x}_2 = 0 \end{aligned}$$

Discretized the model:

$$\begin{aligned} x_{1,k+1} &= x_{1,k} + a_{imu-x,k}T_s + bT_s \\ x_{2,k+1} &= x_{2,k} \end{aligned}$$

Or:

$$\begin{aligned} x_{1,k+1} &= x_{1,k} + u_kT_s + x_{2,k}T_s \\ x_{2,k+1} &= x_{2,k} \end{aligned}$$

14.1. DIFFERENTIAL DRIVE ROBOT SENSOR FUSION FOR LINEAR AND ANGULAR VELOCITY

In state space form, we have a model:

$$\begin{bmatrix} x_1 \\ x_2 \end{bmatrix}_{k+1} = \begin{bmatrix} 1 & T_s \\ 0 & 1 \end{bmatrix} \begin{bmatrix} x_1 \\ x_2 \end{bmatrix}_k + \begin{bmatrix} T_s \\ 0 \end{bmatrix} u_k \quad (14.9)$$

Or:

$$\begin{bmatrix} V \\ b \end{bmatrix}_{k+1} = \begin{bmatrix} 1 & T_s \\ 0 & 1 \end{bmatrix} \begin{bmatrix} V \\ b \end{bmatrix}_k + \begin{bmatrix} T_s \\ 0 \end{bmatrix} a_{imu-x,k} \quad (14.10)$$

We have a output model:

$$y_k = \begin{bmatrix} 1 & 0 \end{bmatrix} \begin{bmatrix} x_1 \\ x_2 \end{bmatrix}_k = \begin{bmatrix} 1 & 0 \end{bmatrix} \begin{bmatrix} V \\ b \end{bmatrix}_k \quad (14.11)$$

Check observability:

$$obs = \begin{bmatrix} C \\ CA \end{bmatrix}$$

We have:

$$A = \begin{bmatrix} 1 & T_s \\ 0 & 1 \end{bmatrix} \text{ and } C = \begin{bmatrix} 1 & 0 \end{bmatrix}$$

$$\rightarrow obs = \begin{bmatrix} 1 & 0 \\ 1 & T_s \end{bmatrix} \text{ is full rank} = \text{observable.}$$

Apply Kalman Filter on the system

Initialize:

- $\hat{x}_{0|0} = \begin{bmatrix} 0 \\ 0 \end{bmatrix}$
- $P_{0|0} = \begin{bmatrix} 1 & 0 \\ 0 & 1 \end{bmatrix}$
- $A = \begin{bmatrix} 1 & T_s \\ 0 & 1 \end{bmatrix}$
- $B = \begin{bmatrix} T_s \\ 0 \end{bmatrix}$
- $C = \begin{bmatrix} 1 & 0 \end{bmatrix}$
- $Q = \begin{bmatrix} 0.00001 & 0 \\ 0 & 0.00001 \end{bmatrix}$
- $R = \begin{bmatrix} 0.00001 & 0 \\ 0 & 0.00001 \end{bmatrix}$
- $u_k = a_{imu-x,k}$
- $y_k = V_{encoder,k}$

Time Update

$$\begin{aligned}\hat{x}_{k+1|k} &= A\hat{x}_{k|k} + Bu_k \\ P_{k+1|k} &= AP_{k|k}A^T + Q\end{aligned}$$

Measurement Update

$$\begin{aligned}\hat{y}_{k+1|k} &= C\hat{x}_{k+1|k} \\ P_{xy,k+1|k} &= P_{k+1|k}C^T \\ P_{yy,k+1|k} &= CP_{k+1|k}C^T + R \\ \hat{x}_{k+1|k+1} &= \hat{x}_{k+1|k} + P_{xy,k+1|k}P_{yy,k+1|k}^{-1}(y_k - \hat{y}_{k+1|k}) \\ P_{k+1|k+1} &= P_{k+1|k} - P_{xy,k+1|k}P_{yy,k+1|k}^{-1}P_{xy,k+1|k}^T\end{aligned}$$

14.1.4 Estimate ω

From model:

$$\begin{aligned}\omega_{k+1} &= \omega_{imu-z} + b_k \\ b_{k+1} &= b_k\end{aligned}\tag{14.12}$$

Let:

$$\begin{aligned}x_1 &= \omega \rightarrow \dot{x}_1 = 0 \\ x_2 &= b \rightarrow \dot{x}_2 = 0\end{aligned}$$

Discretized the model:

$$\begin{aligned}x_{1,k+1} &= \omega_{imu-z} + b_k \\ x_{2,k+1} &= b_k\end{aligned}$$

Or:

$$\begin{aligned}x_{1,k+1} &= u_k + x_{2,k} \\ x_{2,k+1} &= x_{2,k}\end{aligned}$$

In state space form, we have a model:

$$\boxed{\begin{bmatrix} x_1 \\ x_2 \end{bmatrix}_{k+1} = \begin{bmatrix} 0 & 1 \\ 0 & 1 \end{bmatrix} \begin{bmatrix} x_1 \\ x_2 \end{bmatrix}_k + \begin{bmatrix} 1 \\ 0 \end{bmatrix} u_k}\tag{14.13}$$

Or:

$$\boxed{\begin{bmatrix} \omega \\ b \end{bmatrix}_{k+1} = \begin{bmatrix} 0 & 1 \\ 0 & 1 \end{bmatrix} \begin{bmatrix} \omega \\ b \end{bmatrix}_k + \begin{bmatrix} 1 \\ 0 \end{bmatrix} \omega_{imu-z}}\tag{14.14}$$

We have a output model:

$$\boxed{y_k = \begin{bmatrix} 1 & 0 \end{bmatrix} \begin{bmatrix} x_1 \\ x_2 \end{bmatrix}_k = \begin{bmatrix} 1 & 0 \end{bmatrix} \begin{bmatrix} \omega \\ b \end{bmatrix}_k}\tag{14.15}$$

Check observability:

$$obs = \begin{bmatrix} C \\ CA \end{bmatrix}$$

We have:

$$A = \begin{bmatrix} 0 & 1 \\ 0 & 1 \end{bmatrix} \text{ and } C = [1 \quad 0]$$

$$\rightarrow \text{obs} = \begin{bmatrix} 1 & 0 \\ 0 & 1 \end{bmatrix} \text{ is full rank} = \text{observable.}$$

Apply Kalman Filter on the system

Initialize:

- $\hat{x}_{0|0} = \begin{bmatrix} 0 \\ 0 \end{bmatrix}$
- $P_{0|0} = \begin{bmatrix} 1 & 0 \\ 0 & 1 \end{bmatrix}$
- $A = \begin{bmatrix} 0 & 1 \\ 0 & 1 \end{bmatrix}$
- $B = \begin{bmatrix} 1 \\ 0 \end{bmatrix}$
- $C = [1 \quad 0]$
- $Q = \begin{bmatrix} 0.00001 & 0 \\ 0 & 0.00001 \end{bmatrix}$
- $R = \begin{bmatrix} 0.00001 & 0 \\ 0 & 0.00001 \end{bmatrix}$
- $u_k = \omega_{imu-z}$
- $y_k = \omega_{encoder,k}$

Time Update

$$\begin{aligned} \hat{x}_{k+1|k} &= A\hat{x}_{k|k} + Bu_k \\ P_{k+1|k} &= AP_{k|k}A^T + Q \end{aligned}$$

Measurement Update

$$\begin{aligned} \hat{y}_{k+1|k} &= C\hat{x}_{k+1|k} \\ P_{xy,k+1|k} &= P_{k+1|k}C^T \\ P_{yy,k+1|k} &= CP_{k+1|k}C^T + R \\ \hat{x}_{k+1|k+1} &= \hat{x}_{k+1|k} + P_{xy,k+1|k}P_{yy,k+1|k}^{-1}(y_k - \hat{y}_{k+1|k}) \\ P_{k+1|k+1} &= P_{k+1|k} - P_{xy,k+1|k}P_{yy,k+1|k}^{-1}P_{xy,k+1|k}^T \end{aligned}$$

14.2 Three Wheels Omnidrive Robot Sensor Fusion for Linear and Angular Velocity

We have a model:

$$\begin{aligned}
 \dot{V}_x &= a_{imu-x} + b_x \\
 \dot{V}_y &= a_{imu-y} + b_y \\
 \dot{b}_x &= 0 \\
 \dot{b}_y &= 0
 \end{aligned} \tag{14.16}$$

Let:

$$\begin{aligned}
 x_1 &= V_x \rightarrow \dot{x}_1 = \dot{V}_x = a_{imu-x} + b_x \\
 x_2 &= V_y \rightarrow \dot{x}_2 = \dot{V}_y = a_{imu-y} + b_y \\
 x_3 &= b_x \rightarrow \dot{x}_3 = \dot{b}_x = 0 \\
 x_4 &= b_y \rightarrow \dot{x}_4 = \dot{b}_y = 0
 \end{aligned}$$

Discretized the model:

$$\begin{aligned}
 x_{1,k+1} &= x_{1,k} + a_{imu-x}T_s + b_xT_s \\
 x_{2,k+1} &= x_{2,k} + a_{imu-y}T_s + b_yT_s \\
 x_{3,k+1} &= x_{3,k} \\
 x_{4,k+1} &= x_{4,k}
 \end{aligned}$$

Or:

$$\begin{aligned}
 x_{1,k+1} &= x_{1,k} + a_{imu-x}T_s + x_{3,k}T_s \\
 x_{2,k+1} &= x_{2,k} + a_{imu-y}T_s + x_{4,k}T_s \\
 x_{3,k+1} &= x_{3,k} \\
 x_{4,k+1} &= x_{4,k}
 \end{aligned}$$

In state space form, we have a model:

$$\boxed{
 \begin{bmatrix} V_x \\ V_y \\ b_x \\ b_y \end{bmatrix}_{k+1} = \begin{bmatrix} x_1 \\ x_2 \\ x_3 \\ x_4 \end{bmatrix}_{k+1} = \begin{bmatrix} 1 & 0 & T_s & 0 \\ 0 & 1 & 0 & T_s \\ 0 & 0 & 1 & 0 \\ 0 & 0 & 0 & 1 \end{bmatrix} \begin{bmatrix} x_1 \\ x_2 \\ x_3 \\ x_4 \end{bmatrix}_k + \begin{bmatrix} T_s & 0 \\ 0 & T_s \\ 0 & 0 \\ 0 & 0 \end{bmatrix} \begin{bmatrix} a_{imu-x} \\ a_{imu-y} \end{bmatrix} \tag{14.17}
 }$$

We have a output model:

$$\boxed{
 y_k = \begin{bmatrix} 1 & 0 & 0 & 0 \\ 0 & 1 & 0 & 0 \end{bmatrix} \begin{bmatrix} x_1 \\ x_2 \\ x_3 \\ x_4 \end{bmatrix}_k = \begin{bmatrix} 1 & 0 & 0 & 0 \\ 0 & 1 & 0 & 0 \end{bmatrix} \begin{bmatrix} V_x \\ V_y \\ b_x \\ b_y \end{bmatrix}_k \tag{14.18}
 }$$

Check observability:

$$obs = \begin{bmatrix} C \\ CA \end{bmatrix}$$

14.2. THREE WHEELS OMNIDRIVE ROBOT SENSOR FUSION FOR LINEAR AND ANGULAR V

We have:

$$A = \begin{bmatrix} 1 & 0 & T_s & 0 \\ 0 & 1 & 0 & T_s \\ 0 & 0 & 1 & 0 \\ 0 & 0 & 0 & 1 \end{bmatrix} \text{ and } C = \begin{bmatrix} 1 & 0 & 0 & 0 \\ 0 & 1 & 0 & 0 \end{bmatrix}$$
$$\rightarrow obs = \begin{bmatrix} 1 & 0 & 0 & 0 \\ 0 & 1 & 0 & 0 \\ 1 & 0 & T_s & 0 \\ 0 & 1 & 0 & 1 \end{bmatrix} \text{ is full rank = observable.}$$